

DLD SERIES

Drum Louver Diffusers



APPLICATION

Ruskin DLD series supply diffuser systems are designed to provide an air distribution system with the benefit of having directional air control. The system is ideal for open ceiling applications that need single point supply air with long throws. The Drum Louver allows you to "spot" the air where you need it most.

STANDARD CONSTRUCTION

Diffuser Frame	Aluminum.
Drum Louver	Extruded aluminum.

ENGINEERING DATA

Model #	CFM	30° Deflection			0° Deflection		
		Noise	Static	Throw	Noise	Static	Throw
DLD-1506	1200-2000	<30	0.420	12-16	<25	0.29	16-20
DLD-2010	4000-5000	<45	0.420	34-37	<40	0.29	40-45
DLD-2510	6000	<45	0.508	39	<40	0.33	48
DLD-3510	8000	<45	0.440	47	<40	0.30	63
DLD-4010	10000	<45	0.528	46	<40	0.33	62
DLD-5010	12000	<45	0.543	56	<40	0.35	72

DIMENSIONAL DATA

Model #	A	B	C	Grille Size	Unit Weight
DLD-1506	24.625	22.500	9.000	15 x 6	47.00
DLD-2010	29.625	27.500	13.000	20 x 10	53.00
DLD-2510	34.625	32.500	13.000	25 x 10	62.00
DLD-3510	44.625	42.500	13.000	35 x 10	91.00
DLD-4010	49.625	47.500	13.000	40 x 10	124.00
DLD-5010	59.625	57.500	13.000	50 x 10	151.00

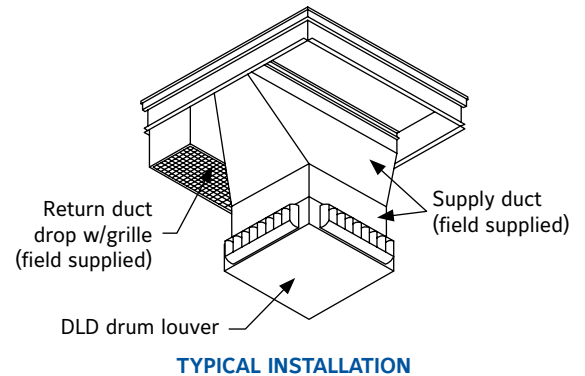

FEATURES

- ▶ Lightweight aluminum construction
- ▶ Drum louver diffusers for high installations
- ▶ Internal air deflector
- ▶ Built in Duct Cap with hanging support

SUGGESTED SPECIFICATION

Furnish and install, at locations shown on plans or in accordance with schedules, drum louver diffusers manufactured in an ISO9001 facility. Drum louver diffusers shall be aluminum construction and incorporate an internal air deflector to ensure quiet, even airflow to all sides with low pressure drop. Bottom panel of drum louver diffuser assembly shall have polyester resin powder coat finish to match grille. Drum louver diffuser shall provide minimum 30° vertical adjustment and full horizontal blade adjustment providing single point supply air for large space applications. Manufacturers published data sheet shall include CFM rating, noise, static, and throw information. Drum louver diffuser shall be in all respects equivalent to Ruskin Model DLD.

Built in Duct Cap with hanging supports

Furnish drum louver diffuser complete with duct cap accessory. Duct cap shall be insulated and designed to mate with the diffuser. Integral hanging supports shall be part of the duct cap accessory.

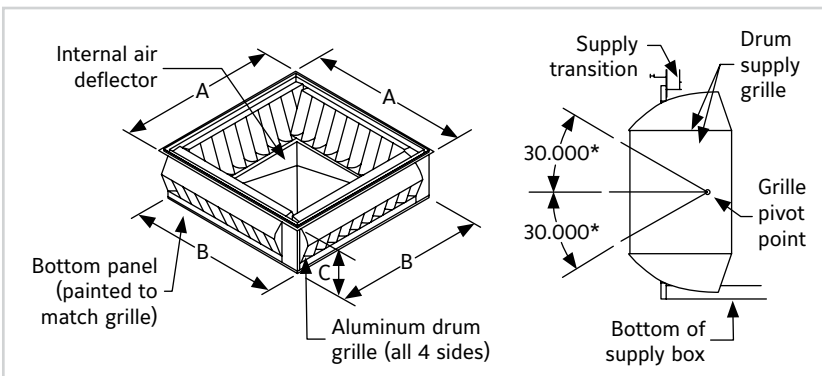

LINKS TO IMPORTANT DOCUMENTS

Document Title
Limited Warranty Document



3900 Doctor Greaves Road
Grandview, MO 64030
Website: www.ruskin.com
Phone: (816) 761-7476