

Powers™ Controls

OEM Literature

No. 6 Pneumatic Damper Actuator

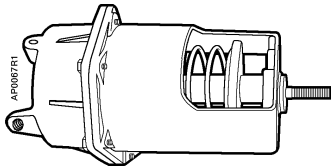

Basic Actuator

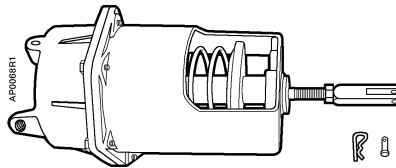

Typical Actuator with Clevis and Pin

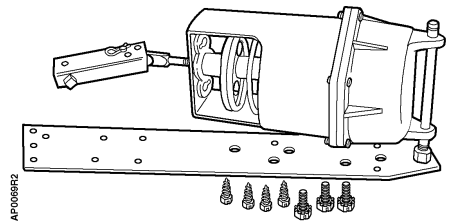

Actuator with Extended Shaft and
Frame Mounting Accessories

Description

The No. 6 Pneumatic Damper Actuator is a heavy duty, rolling diaphragm, spring return actuator designed to drive large dampers, centrifugal fan inlet vanes, and other applications requiring a large effective diaphragm area and long stroke.

Features

- Replaceable ozone resistant rolling diaphragm
- Pivot mounting for extended shaft or frame mounting
- Positioning relay (optional)
- Adjustable forward travel stops (optional)
- Three spring ranges

Product Numbers

See Table 1

Application

The No. 6 Pneumatic Damper Actuator is recommended for control of outdoor, return air, exhaust, face and bypass, and fan discharge dampers. It is recommended for heavy duty applications using multi-section dampers where either unison or sequence operation is required.



Certain actuators in Table 1 are UL Recognized Components under UL's Damper Actuator category (EMKU2). This category covers pneumatic damper actuators intended to be employed on fire dampers and fire/smoke leakage rated dampers.

Table 1. Product Numbers for No. 6 Pneumatic Damper Actuators.

Description	Mounting Style	Part Number		
		Nominal Spring Range		
		3-8 psi (21-55 kPa)	3-13 psi (21-90 kPa)	8-13 psi (55-90 kPa)
Basic Actuator only	Pivot	331-2793	331-2794	331-2792*
Actuator, with forward travel stops (Figure 2)	Pivot	—	331-2796	331-2795
Pivot Mount Actuator with clevis, clevis pin, and hitch pin clip	Pivot	331-2857	331-2858	331-2856*
Same as above with positioner (Figure 5)	Pivot	—	—	332-2856
Actuator and manufacturing assembly for extended shaft and frame mounting	Universal kit	331-3012	331-3013	331-3011*
Same as above with positioner (Figure 5)	Universal kit with positioner	—	—	332-3011
Extended Temperature Range Model (Basic Actuator only)	—	—	—	331-3060*

* UL Recognized Component.

NOTE: Kits must be ordered separately from damper manufacturer.

Specifications	
Effective Diaphragm Area	17.9 inch ² (115 cm ²)
Stroke	4 inches (102 mm)
Housing	Aluminum
Shaft	Stainless steel
Maximum Air Pressure	30 psig (210 kPa)
Nominal Spring Ranges	3 to 8 psi (21 to 55 kPa) 3 to 13 psi (21 to 90 kPa) 8 to 13 psi (55 to 90 kPa)
Ambient Temperature Range	-20 to 160°F (-29 to 71°C)
Air Connection	1/8 inch NPT
Type of Mounting	Pivot
Thrust and Torque Rating	See Table 2
Dimensions	See Figures 3 through 6
Agency Approvals	Complies with UL555 and UL555S

Table 2. Thrust Torque Ratings.

Nominal Spring Range	Maximum Thrust lbs. (N)				Torque Rating* lb-in (Nm)			
	Full Stroke Forward			Spring Return (No Stroke) 0 psi (0 kPa)	Gradual Operation	2-Position Operation or Positioner		
	15psi (103 kPa)	18 psi (124 kPa)	25 psi (172 kPa)			15 psi (103 kPa)	18 psi (124 kPa)	25 psi (172 kPa)
3-8 psi (21-55 kPa)	125 (556)	179 (796)	304 (1352)	54 (240)	50 (5.6)	75 (8.5)	75 (8.5)	75 (8.5)
3-13 psi (21-90 kPa)	36 (160)	89 (396)	214 (952)	54 (240)	50 (5.6)	50 (5.6)	75 (8.5)	75 (8.5)
8-13 psi (55-90 kPa)	36 (160)	89 (396)	214 (952)	144 (640)	50 (5.6)	50 (5.6)	125 (14)	202 (23)

* With maximum hysteresis of 2.5 psi (17.2 kPa) @ 90° rotation.

NOTE: The No. 6 Pneumatic Damper Actuator does not require any periodic cycling. However, it is strongly suggested that all systems are functionally checked periodically, and per local codes and ordinances.

Accessories	Damper shaft extension kits:	
	1/2-inch (13 mm) diameter (See <i>TB-128</i>)	331-631
	1/2-inch (13 mm) diameter, 9-inch (229 mm) long, hollow rod	333-184
	1/2-inch (13 mm) diameter, 9-inch (229 mm) long	333-042
	Actuator shaft extensions:	
	10-1/8 inch (257 mm) long	331-434A
	Adapter kit for 1/2 inch NPT pipe	333-030
	Damper shaft extension kit adapter - 3/8 inch (9.5 mm)	331-632
	Crank—damper shaft:	
	3/8-inch (9.5 mm) - 1/2 inch (13 mm) diameter, selectable radius	331-941
	5/8-inch (16 mm) diameter	333-182
	3/4-inch (19 mm) diameter	333-183
	1-inch (25 mm) diameter	333-181
	Cast iron crank with setscrews	333-078
	Linkage kit (4-inch, 102 mm, link and crank)	331-958
	Remote mounting kit (extended shaft)	331-618
	Universal mounting plate	331-623
	Positioning relay	147-2000
	Positioning relay mounting kit	147-276
	Frame mounting kits	
	One-section damper	331-833*
	Two-section damper	331-834*
	Three-section damper	331-835*
	Damper blade clip kit	331-838*
	Mounting lug	331-569
	Offset mounting bracket	333-176
	Travel stop rods	333-197
* Order Frame Mounting Kits from your Siemens Building Technologies, Inc. representative.		
Service Kits	Diaphragms:	
	Standard	331-071
	Heavy Duty (High Temperature to 450°F (232°C))	331-0771A

Actuator Sizing

The quantity of actuators required depends on several torque factors. To determine the quantity of actuators required for the installation:

1. Obtain damper torque ratings (ft-lb/ft²) from the damper manufacturer.
2. Determine the area of the damper.
3. Calculate the total torque required to move the damper:

$$\text{Total Torque} = \text{Torque Rating} \times \text{Damper Area}$$

4. Calculate the total quantity of actuators required:

$$\text{Number of Actuators} = \frac{\text{Total Damper Torque Required}}{\text{SF}^1 \times \text{Actuator Torque (Table 2)}}$$

Safety Factor

- ¹ Safety Factor: When calculating the number of actuators required, a safety factor should be included for unaccountable variables such as slight misalignments, aging of the damper, etc. A suggested safety factor is 0.80 (or 80% of the rated torque).

See *AB-300 Damper Actuator Sizing and Selection Application Bulletin in the HVAC Systems/Controls Reference Data (125-1853)* for additional sizing information. See *TB-181 Powers™ Controls Maximum Thrust Ratings of Pneumatic Damper Actuators Technical Bulletin (155-219P25)* for additional torque requirements.

Operation

Standard Actuator (Figure 1)

The air tubing from a controlling instrument is connected to the actuator's upper housing. With no control pressure to the actuator, the compression spring forces the spring seat and actuator shaft toward the upper housing but is limited by the E"-ring. As the control pressure increases, the spring compression is overcome and the actuator shaft gradually moves outward. Conversely, as control pressure decreases, the spring returns the shaft to the position at which the air pressure on the diaphragm balances the spring tension. For each value of control pressure there is a corresponding position of the shaft

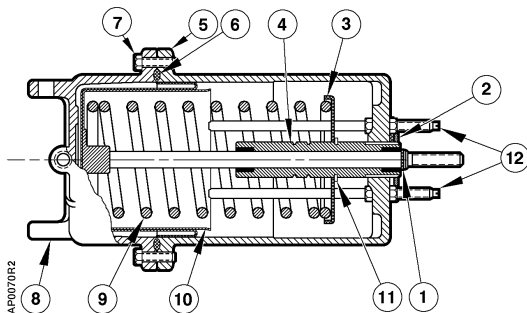

Figure 1. Standard Actuator.

Table 3. Construction Components (Figure 1).

Item	Part No.	Description	Qty.	Material
1	047-061J	Retaining E-ring	1	Steel
2	333-217	1 x 1-1/4 in. Hex Nut	1	Brass
3	—	Spring Retainer	1	—
4	—	Stem Guide Assembly	1	—
5	—	Lower Housing	1	Aluminum
6	333-206 (pkg. of 5)	Diaphragm	1	—
7	599-00413	5/16 in.-18 x 1 Large Hex Cap Screw	6	Steel
8	—	Upper Housing	1	Aluminum
9	—	Helical Compression Spring	1	—
	331-091	3 to 13 psi (21 to 90 kPa)		—
	331-208	3 to 8 psi (21 to 55 kPa)		—
	331-094	8 to 13 psi (55 to 90 kPa)		—
10	—	Piston Plate and Stem Assembly	1	Aluminum/ Stainless Steel
11	—	Retaining C-ring	1	Steel
12	333-197	Stop Kit	—	Steel

**Operations,
 Continued**

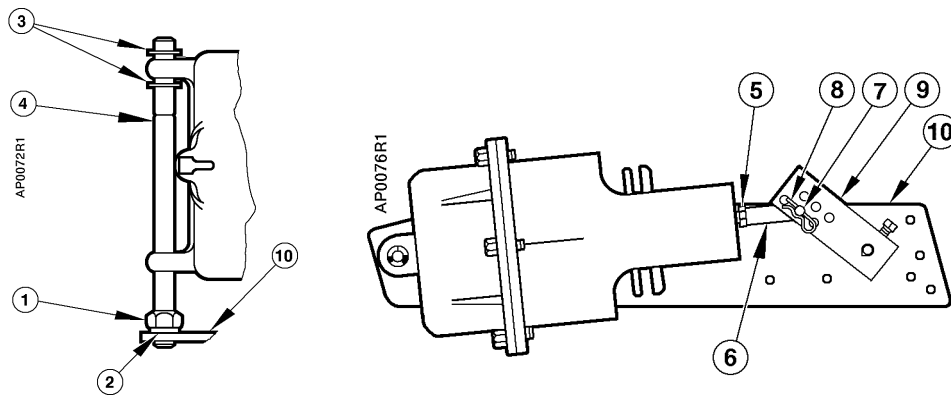

Figure 2. Extended Shaft/Frame Mounting Actuator Assembly.

Table 4. Extended Shaft/Frame Mounting Assemblies (Figure 2).

Item	Part No.	Description	Qty.	Material
1	041-162J	Nut	1	Steel
2	146-020K	Lock washer	1	Steel
3	047-061K	E-ring	2	Steel
4	331-565	Pivot post	1	Steel
5	041-142	Nut	1	Steel
6	333-207	Clevis	1	Zinc plated steel
7	331-293	Clevis pin	1	Zinc plated steel
8	331-807	Hitch pin	1	Zinc plated steel
9	331-941	Crank assembly	1	Zinc plated steel
10	331-623	Actuator mounting plate	1	Steel
—	034-283	Mounting screws	4	Steel
F	333-034	Rocker	—	Zinc plated steel
F	034-123K	Mounting screws	3	Steel
F	041-230J	Nut	2	Steel
F	030-510J	Screws	2	Steel

“F” Parts for Frame Mounting.

Dimensions

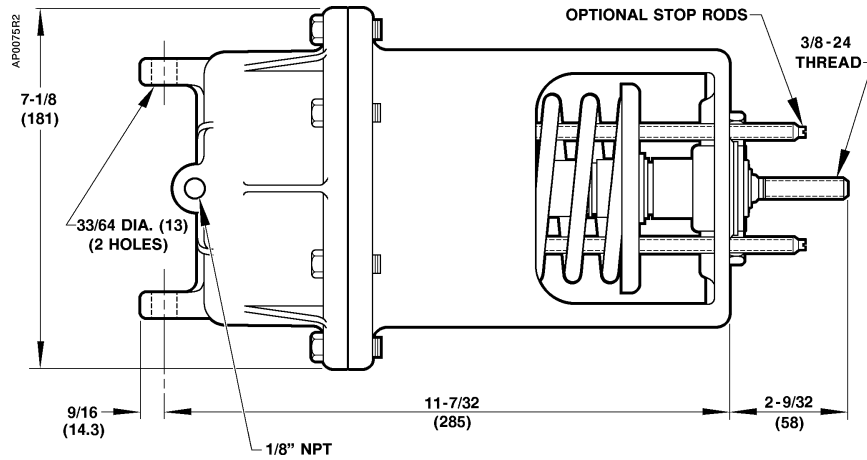

Figure 3. Dimensions Shown in Inches (mm).

Offset Mounting Bracket

This bracket is designed to offset the Universal Mounting Plate 331-623 from ductwork.

NOTE: Depending on the application, two brackets may be required to support the actuator and universal mounting plate.

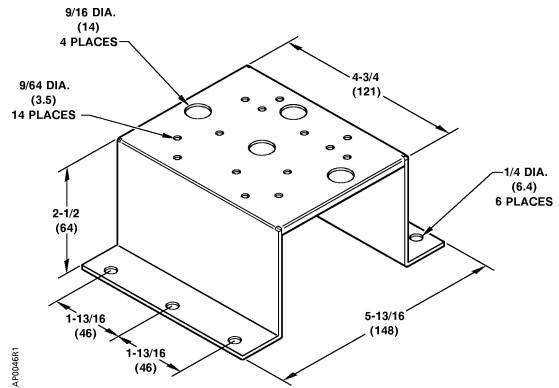

Figure 4. Offset Mounting Bracket 331-186. Dimension in Inches (mm).

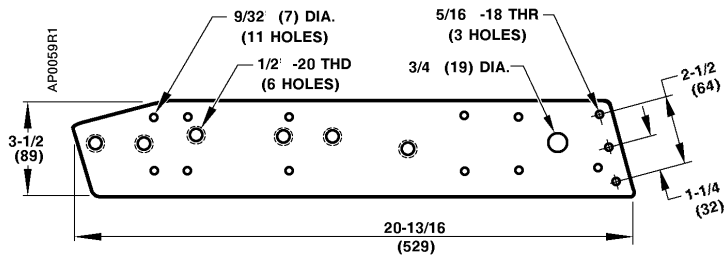
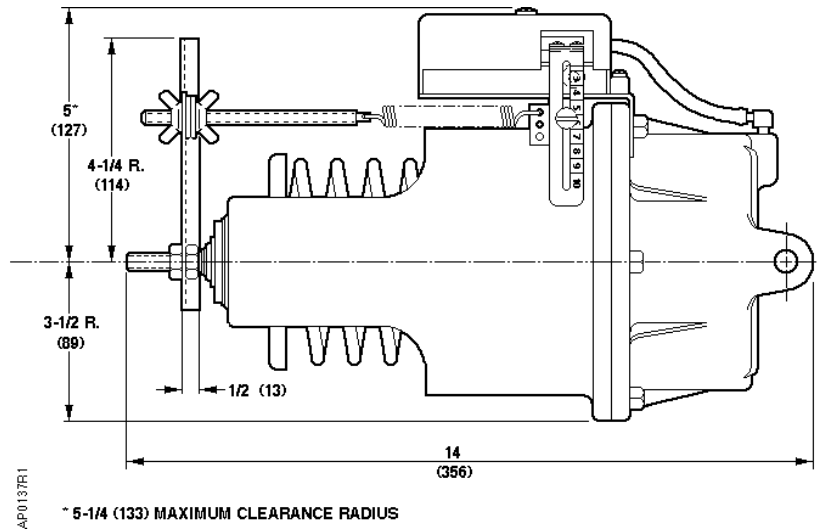

Figure 5. Actuator Mounting Plate. Dimensions in Inches (mm).

**Dimensions,
 Continued**



**Figure 6. No. 6 Pneumatic Damper Actuator with the RL 147 Positioning Relay Mounted.
 Dimensions in Inches (mm).**

Information in this publication is based on current specifications. The company reserves the right to make changes in specifications and models as design improvements are introduced. Powers is a trademark of Siemens Building Technologies, Inc. Other product or company names mentioned herein may be the trademarks of their respective owners. © 2001 Siemens Building Technologies, Inc.