

CDRAMS

Round Air Measuring Station with Integral Control Damper



APPLICATION

The CDRAMS combines an air measuring station with a round ultra low-leak control damper that was developed to meet the industry requirements for an air measuring station for use in spiral duct applications. The specially designed blade-to-frame, full circumference seal is mechanically fastened between a dual skin blade. The flow sensing cross samples the air pressure across the full diameter of the duct. The complete unit is factory assembled and tested to provide effective setpoint monitoring and adjustment. The unit comes standard with a pressure transducer (shipped loose). The output signal is proportional to flow. The output signal can be read with a volt meter to position the damper at the desired set point. Automated control options are available.

STANDARD CONSTRUCTION

Frame	20 gauge (1.0) galvanized steel.
Flow Sensing Cross	One-piece ABS plastic flow cross on units 6" (152) diameter through 16" (406) diameter.
	Two-piece anodized aluminum extrusion on units 18" (457) diameter through 24" (610) diameter.
Accuracy	+/- 5% of flow.
Sensor Port Fittings	Brass fittings (for CDRAMS units with the two-piece anodized aluminum extrusion flow cross).
Pressure Transducer	RU-274-R2-VDC; 0-5 or 0-10 VDC output field selectable. Output signal is proportional to flow.
Power Requirements	12-40 VDC or 12-35 VAC.
Damper Blade	Dual-skin galvanized steel.
Blade Seal	Full circumference neoprene seal, mechanically fastened between dual blade skins.
Axle	.50" (13) dia. plated steel, extended 6" (152) from frame O.D.
Bearings	Stainless steel sleeve.
Damper Sizes	Diameters (D) 6", 7", 8", 9", 10", 12", 14", 16", 18", 20", 22", 24" (152, 178, 203, 229, 254, 304, 356, 406, 457, 508, 559, 610).
	Frame Lengths (L) 6" dia. - 10" dia. (152 - 254) L = 17" (432). Above 10" dia. - 20" dia. (254 - 508) L = 27" (686). Above 20" dia. - 24" dia. (508 - 610) L = 31" (787).
	Product Range - 400 to 4000 FPM (2 to 20 M/s). Operating Range - 400 to 2,000 FPM (2 to 10.2 M/s). - Units with standard RU274-R2-VDC transducer - Units with optional AMS8100-LR transducer - Standard units with RU274-R2-VDC transducer. Operating Range - 400 to 4,000 FPM (2 to 20 M/s) - Units with optional transducers model AMS8100 or DPT-IQ - Units with optional VAFB24-BAC or VAMB24-BAC air measurement actuator.
Velocity Requirements	
Operating Temperature	Minimum -40°F (-40°C). Maximum 200°F (93°C).
Finish	Mill galvanized frame and damper blade.

Application Hint:

Perfect for manually balancing a branch take-off. Or order with a BACnet Air Measurement Actuator (spring return VAFB24-BAC or fail in-place VAMB24-BAC) in lieu of a VAV or Constant Volume box for Lab HEPA filter applications.



Units shown above are representative of units 6" diameter through 16" diameter.



FEATURES

- ▶ Low Pressure Transducer model RU274-R2-VDC; shipped loose
 - ▶ Ultra low-leak damper
 - ▶ Available from 6" to 24" (152 to 610) diameter
- Ruskin CDRAMS helps satisfy the requirements for minimum outside air as required by the following.
- ▶ ASHRAE 62.1, 90.1 and 189.1
 - ▶ California Title 24
 - ▶ International Mechanical Code (IMC)
 - ▶ International Energy Conservation Code (IECC)

VARIATIONS

Ruskin model CDRAMS is available with the following variations at additional cost

- ▶ Anodized aluminum sensing blades
- ▶ Factory mounted 24VAC modulating actuator
- ▶ Manual hand quadrant for locking damper blade in desired position
- ▶ Transducer models AMS8100-LR and AMS8100; each offers LCD Display
- ▶ DPT-IQ Transducer with backlit LCD Flow and Pressure display
- ▶ Actuator mounting bracket for field mounted, customer-furnished actuator
- ▶ Aluminum construction
- ▶ Stainless steel 304SS or 316SS construction
- ▶ Silicone, EDPM or viton seals
- ▶ Factory mounted air measurement actuator (VAFB24-BAC or VAMB24-BAC)

NOTES:

- Values shown in parenthesis () indicate metric units.
- Units furnished approximately .125" (3) smaller than given opening diameter.

DIMENSIONAL DETAILS

- Specify "D" diameter (length is determined by diameter).
- The standard transducer is field selectable 0-5 or 0-10 VDC output.
Specify an AMS8100 transducer as required.
 - 4-20 mA output or 0-5 VDC or 0-10 VDC (field selectable)
 - LCD display (displays dp)
 - High pressure applications on units over 1" (248 Pa) w.g.
- Specify the means of damper control.
 - Manual operation requires a manual locking hand quadrant.
 - BAS-controlled damper may have either a customer furnished actuator or Ruskin furnished modulating 24 volt actuator. Special actuators available upon request (consult factory).
 - Flow control applications require Ruskin's VAFB24-BAC (spring return) or VAMB24-BAC (maintain last command) BACnet air measurement actuator with control. Specify the design setpoint CFM (l/s), along with a low and high limit CFM (l/s) when ordering this option. The low limit CFM (l/s) is generally set to the ASHRAE62.1 design for the space. The high limit is generally based on future occupancy or purge requirements. Design is a value that is between the low and high limits. Often, the design is the same as the low limit, since you should never operate below the ASHRAE minimum requirement in the space.
 - Actuator by others - Ruskin offers a universal mounting bracket as an optional feature.

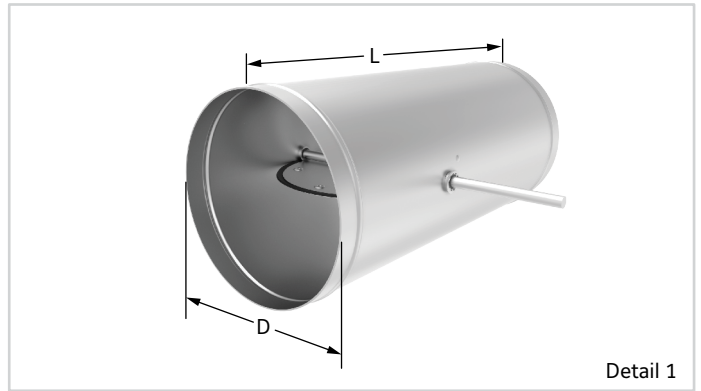

CDRAMS Diameter (D)	Length of Frame (L)
6" thru 10" (152mm thru 254mm)	17" (432mm)
Above 10" thru 20" (Above 254mm thru 508mm)	27" (686mm)
Above 20" thru 24" (Above 508mm thru 640mm)	31" (787mm)

Construction shown with ABS flow measuring cross (sizes 6" through 16" diameter)

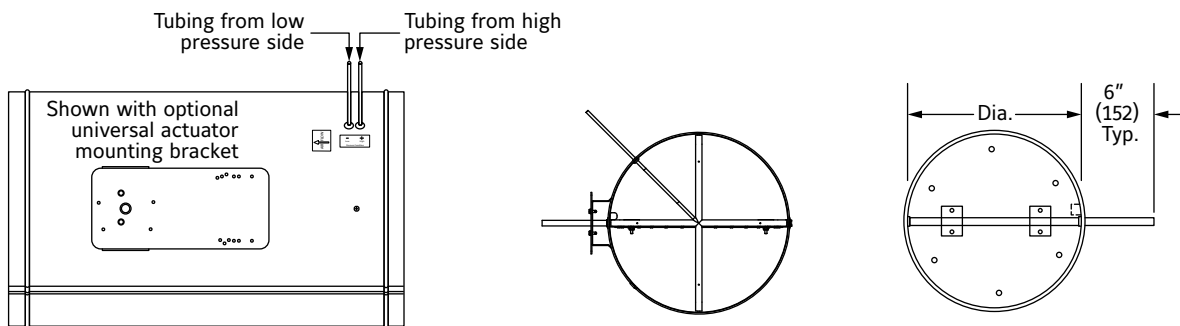

Construction details below shown with anodized aluminum flow measuring cross (sizes greater than 16" through 24" diameter)

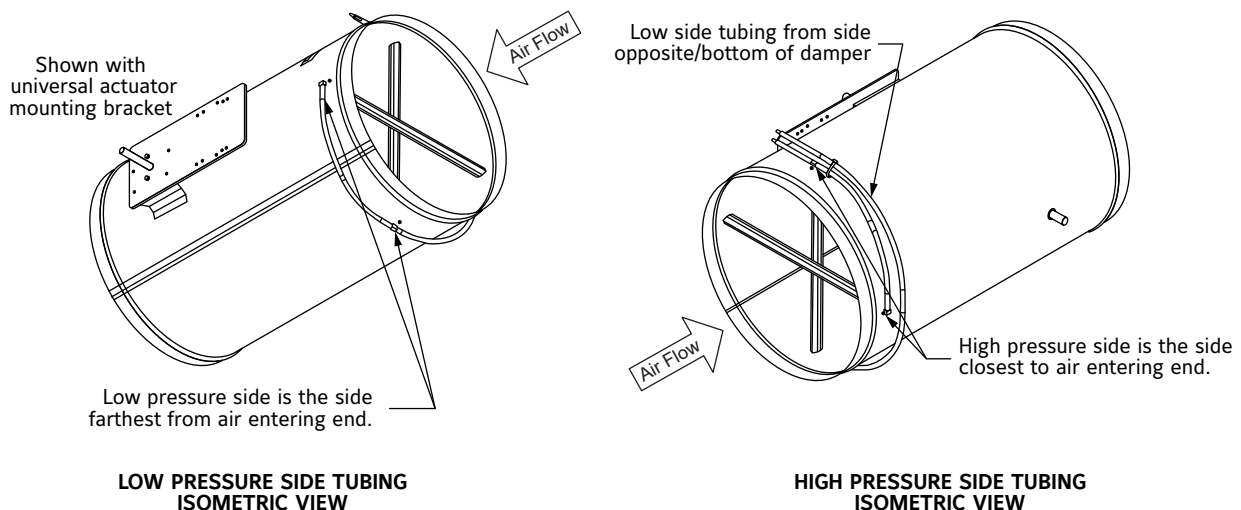

INSTALLATIONS

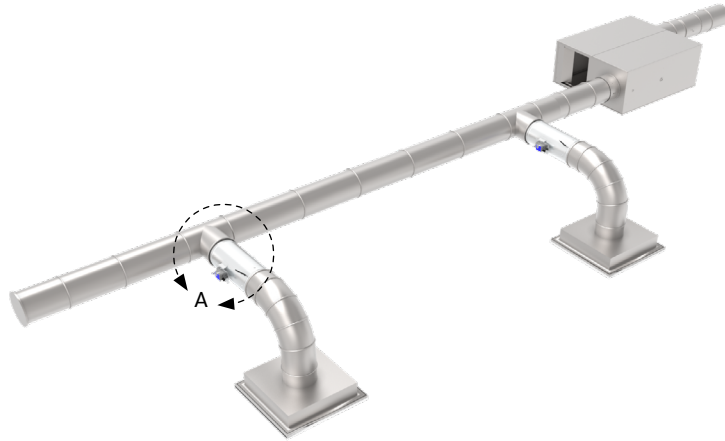

CDRAMS with normal 24V modulating actuator

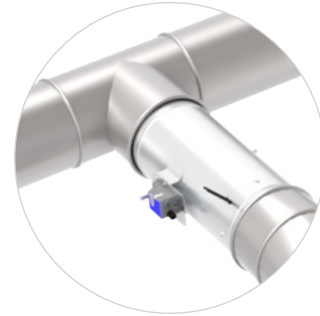

Section A



CDRAMS with air measuring actuator VAFB24-BAC

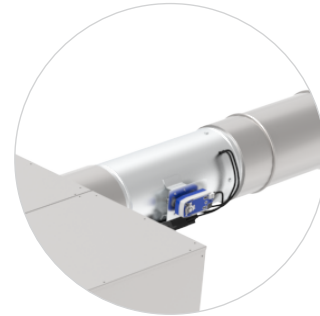

Section A

Installation Instructions

First, identify location in existing ductwork for installation of the CDRAMS. The installation location should provide enough clearance to accommodate the frame length of the CDRAMS. See Damper Length (L) information under Standard Construction on page 1 of this document.

Inspect the ductwork and/or the opening where the CDRAMS Damper will be installed for any obstructions or irregularities that might interfere with the proper operation of the damper blade or actuator, if applicable. When installed in the ductwork, the ductwork should be supported in the area of the CDRAMS damper to prevent sagging which could negatively affect the performance of the damper. Insert the CDRAMS assembly into the duct, making sure the airflow measuring cross is upstream of the damper blade. Utilizing 10-16 x 3/4" (19) Long tek screws, secure the CDRAMS to the duct.

After installing the assembly in the ductwork, caulk around the CDRAMS frame to ensure that there is no leakage or bypass around the air measuring station.

Mount the pressure transducer at a location convenient to the installation and pipe (connect) the CDRAMS high & low pressure tubes to the transducer's pressure ports. Ensure the high pressure tube is connected to the high pressure port and the low pressure tube is connected to the low pressure port. Use the formula shown in the Suggested Specifications section below to determine flow (CFM).

SUGGESTED SPECIFICATION

Multi-Point Center Averaging

Multi-point center averaging flow probes take the pressure readings at the center of the assembly. Center averaging improves performance because they are not as affected by poor inlet conditions when compared to linear averaging flow devices. This is because each total pressure port has the same "weight" in determining the pressure reading. In contrast, the total pressure port closest to the point where the reading is taken will have a higher "weight" than the port that is farthest away from the reading.

$$CFM (l/s) = (Area \times K_a) \times \sqrt{PAMS}$$

K-Factors	
Inlet Size	Ka
6" (152)	2282
7" (178)	2496
8" (203)	2590
9" (229)	2642
10" (254)	2633
12" (305)	2408
14" (356)	2820
16" (406)	2749
18" (457)	3450
20" (508)	3450
22" (559)	3050
24" (610)	3200

Amplification

Amplification is the ability of the flow probe to produce a signal greater than the velocity pressure. Pitot tubes read true velocity pressure, which requires 4005 FPM (20.3 m/s) to produce a 1" w.g. signal. Velocity pressure is the difference between total pressure and static pressure. Amplified flow probes improve upon this signal by taking the difference between total pressure and a reduced static pressure. Amplification is critical to accurate control of minimum flow rates. The CDRAMS is capable of providing a signal of sufficient magnitude for any type of controller to monitor easily.

$$Area = \pi R^2 / 144$$

$$PAMS = \text{Velocity Pressure Inches Water Gauge (Pa)}$$

Sensitivity

Inlet sensitivity is a measure of flow sensing accuracy that can be lost to less than ideal inlet conditions. SMACNA recommends a minimum of three duct diameters of straight duct in front of any flow measuring device. This is not generally the standard practice on many job sites. Duct obstructions result in jogs and turns in both rigid and flexible supply duct. Real world conditions require a flow probe that is capable of measuring air volume to a +/- 5% accuracy, regardless of inlet conditions. If excessive inlet sensitivity results in a reduced flow signal for a given flow volume, the benefit of amplification has been lost. Regardless of sophistication, no controller can overcome less than adequate accuracy from a flow sensor under common field conditions.

The CDRAMS Flow Station has less inlet sensitivity than any other flow probe on the market, with no more than +/- 5% error regardless of inlet condition. In contrast, other center-averaging designs are capable of +/- 10% error. Linear averaging designs can range from +/- 10% to 35% depending on exact condition and angle of approach.

For units from 6" (152) to 16" (406) with ABS flow cross:

Furnish and install, at locations shown on plans or in accordance with schedules, a true round air measuring station with integral control damper and pressure transducer which is shipped loose for field positioning. Device shall incorporate a cross shaped, multi-point, center averaging sensor, made of a high impact ABS material. Flow probe shall output an amplified differential pressure signal that is at least 1.5 times the equivalent velocity pressure signal obtained from a conventional pitot tube and be capable of measuring air volume to a +/- 5% accuracy. The complete air measuring package shall be factory assembled into a turnkey product capable of sending a 0-10 VDC output signal that is proportional to CFM (l/s). Unit shall have a measuring range from 400 to 4,000 feet per minute (2 to 20.3 meters per second). Units equipped with the standard transducer shall have a measuring range from 400 to 2,000 feet per minute (2 to 10.2 meters per second). The standard transducer shall include a glass-on-silicone GL-Si capacitance sensor capable of measuring up to six field selectable pressure ranges up to 1" (249 Pa) water column. The transducer shall be accurate to ±1% of full scale and be contained within a NEMA 4 (IP-65) painted steel enclosure.

The high and low ports of the transducer (shipped loose) should be connected to the sensor averaging ports of the flow cross using the high and low tubing which extends from the CDRAMS frame. The integral damper shall have a full circumference seal, mechanically locked, between dual blade skins. The low profile blade seal shall be an integral part of the damper blade. Seals that are attached to the inside of the damper frame with adhesive or that clip-on, are not acceptable. Axle bearings shall be non-corrosive stainless steel sleeve type and shall be pressed into the damper frame. The damper axle shall be plated steel and shall run the full length of the blade and extend beyond the outside of the frame, a distance no less than 6" (152mm), to accommodate the control device most desirable for the application. Complete assembly shall be constructed, piped and commissioned in an ISO 9001 certified facility. Air Measuring Stations shall be, in all respects, equivalent to Ruskin Model CDRAMS.

Optional AMS8100 high pressure transducer spec for all CDRAMS:

Units equipped with the optional transducer shall have a measuring range from 400 to 4,000 feet per minute (2 to 20.3 meters per second). The transducer shall have an integral LCD display indicating actual differential pressure. The transducer shall have dip switches that allow for field selection of 0-5 VDC, 0-10 VDC or 4-20 mA output signal and have a minimum of five pressure ranges from 0" to 2.5" (0-610 Pa) water column. The transducer shall have an auto zero function that is microprocessor controlled. The transducer assembly shall contain a micro-machined, single-crystal silicon, piezo resistive pressure sensor. Sensor shall digitally compensate for thermal sensitivity. Accuracy of the transducer shall be ±.05% on 0 to 0.1" (0-25 Pa) range and 0.25" (0-62 Pa) range, ±0.25% on all other ranges. Stability shall be ±0.25% (of span selected) per year. Transducer shall be, in all respects, equivalent to Ruskin Model AMS8100.

For units from 18" (457) to 24" (610) with aluminum flow cross:

Furnish and install, at locations shown on plans or in accordance with schedules, a true round air measuring station with integral control damper and field piped pressure transducer. Device shall incorporate a cross shaped, multi-point sensor, made of an aluminum material. Flow probe shall output an amplified differential pressure signal and be capable of measuring air volume to a +/- 5% accuracy. The complete air measuring package shall be factory assembled into a turnkey product capable of sending a 0-10 VDC output signal that is proportional to CFM (l/s). Unit shall have a measuring range from 400 to 4,000 feet per minute (2 to 20.3 meters per second). Units equipped with the standard transducer shall have a measuring range from 400 to 2,000 feet per minute (2 to 10.2 meters per second). The standard transducer shall include a glass-on-silicone GL-Si capacitance sensor capable of measuring up to six field selectable pressure ranges up to 1" (249 Pa) water column. The transducer shall be accurate to ±1% of full scale and be contained within a NEMA 4 (IP-65) painted steel enclosure.

SUGGESTED SPECIFICATION

Transducer shall be mounted and piped through high and low brass pressure fittings to the sensor averaging ports. All sensor tubing shall terminate in solid brass barbed fittings. The integral damper shall have a full circumference seal, mechanically locked, between dual blade skins. The low profile blade seal shall be an integral part of the damper blade. Seals that are attached to the inside of the damper frame with adhesive or that clip-on, are not acceptable. Axle bearings shall be non-corrosive stainless steel sleeve type and shall be pressed into the damper frame. The damper axle shall be plated steel and shall run the full length of the blade and extend beyond the outside of the frame, a distance no less than 6" (152mm), to accommodate the control device most desirable for the application. Complete assembly shall be constructed, piped and commissioned in an ISO 9001 certified facility. Air Measuring Stations shall be, in all respects, equivalent to Ruskin Model CDRAMS.

Optional VAFB24-BAC or VAMB24-BAC Air Measurement BACnet actuators for all CDRAMS

Units equipped with the optional air measurement actuator shall include the high pressure transducer as described in the paragraph on the previous page titled "Optional AMS8100 high pressure transducer spec for all CDRAMS".

In addition, the actuator shall be the BACnet interface and setup port for the air measurement station.

Mode of Operation - Air Measurement Actuator

The air measurement actuator accepts a CFM SETPOINT via analog input S2. The actuator will modulate the damper to maintain the set point value. Airflow measurement sensor is connected to Input S1 of the actuator and represents a velocity air flow measurement. Air measurement is calculated based on actuator's configuration and reported via the BACnet interface or an analog output from the sensor to the building automation system. Air Measurement actuator includes WEB SERVER and can be configured using any web browser such as Internet Explorer.

Direct Position Control via BACnet or Analog Input is also possible, using the flow input for reporting only.

- ▶ Torque 180 in-lb
- ▶ Ethernet 10/100 Mbit/s, TCP/IP, integrated Web server
- ▶ BACnet/IP, BACnet MS/TP
- ▶ Two analog inputs for flow sensing and receiving a DDC setpoint
- ▶ Setup via integrated Web Server and Ethernet IP connection, directly to actuator, using any web browser
- ▶ Fail Safe Signal Interlock, drives damper closed on loss of signal
- ▶ Spring Open, Spring Close, or Fail to Last Position upon loss of power are available as required for the specific application
- ▶ 95 seconds open, less than 60 seconds close
- ▶ NEMA 2, IP54, UL enclosure type 2
- ▶ Built in Data Logging
- ▶ Control up to three additional actuators via MP-Bus

Air Measurement actuator shall be, in all respects, equivalent to Ruskin models VAFB24-BAC or VAMB24-BAC.

LINKS TO IMPORTANT DOCUMENTS

Document Title
Limited Warranty Document



3900 Doctor Greaves Road
Grandview, MO 64030
Website: www.ruskin.com
Phone: (816) 761-7476