

IAQ50X AIR MEASURING STATION WITH INTEGRAL DAMPER AND CALIBRATED CONTROLS

APPLICATION

The IAQ50X is an air measuring station with an ultra low-leak, high performance control damper that is integral to the flow sensing section. This patented design provides a solution that measures and controls flow down to 150 feet per minute (.76 m/s) in an 11" (279) deep assembly. The assembly meets AMCA class 1 leakage requirements, so it is perfect for building envelope penetrations. The complete unit is factory assembled and calibrated at multiple points, to provide effective setpoint monitoring and adjustment. The unit comes standard with an application specific control panel, actuator and a honeycomb air flow straightener. Control with a 0-10 VDC input from the BAS. Provides a 0-10 VDC output that is proportional to the CFM.

STANDARD CONSTRUCTION

FRAME

Nominal 6" x 13/8" (152 x 35) 6063T6 high yield extruded aluminum hat channel with .125" (3.18) wall thickness.

INTEGRAL DAMPER BLADES

Airfoil shaped 6063T6 high yield heavy gauge extruded aluminum.

SENSOR BLADES

Clear Anodized, 6063T6 high yield heavy gauge extruded aluminum.

SENSOR PORT FITTINGS

Brass.

AIR FLOW STRAIGHTENER

1/2" (13) Honeycomb Cell x 3" (76) 3000 series aluminum alloy.

SEALS

Ruskiprene blade edge seals and stainless steel jamb seals. Leakage meets AMCA Class 1 (3 cfm per sq. ft. at 1" w.g.).

BEARINGS

Molded Lexan.

LINKAGE

Plated steel, concealed in frame.

AXLES

1/2" (13) plated steel hex.

POWER REQUIREMENTS

120 Vac, 50/60 Hz to control panel terminal strip.

ELECTRIC ACTUATOR(S)

MS7510IAQ or MS7520IAQ (as required).
24 Vac, 50/60 Hz, powered by control Panel.

CONTROL PANEL

IAQ020 Digital Controller (reference catalog sheet).
Application specific set points factory calibrated.
Program logic & calibration in nonvolatile EPROM.
AMS800 Pressure Transducer.
IAQ080 120Vac/24Vac power transformer (100VA).
18" x 18" x 6" (457 x 457 x 152) Painted Electrical Enclosure.

MINIMUM SIZE

Single -10"w x 10"h (254 x 254).
Multiple section assembly - unlimited.

MAXIMUM SIZE

Single section - 48"w x 84"h (1219 x 2134).
Multiple section assembly - unlimited.

VELOCITY REQUIREMENTS

Product Range 150 to 2000 FPM (Face Area).

OPERATING TEMPERATURE

-22° F to +140° F (-30°C to 60°C) standard.

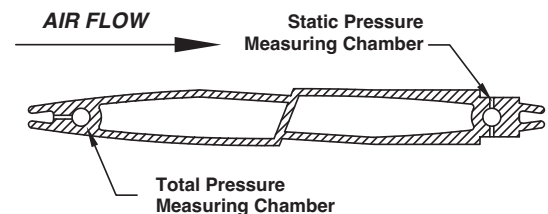
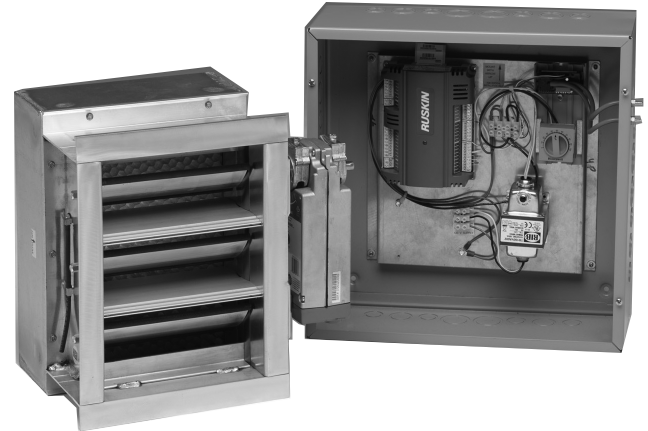

IAQ SENSING BLADE DETAIL

FEATURES

- Honeycomb airflow straightener
- Anodized aluminum sensing blades
- Application specific, factory calibrated controller in nonvolatile EPROM
- 0-10 VDC input
- 0-10 VDC output proportional to CFM
- Flow alarm contacts – LEED EQc1 solution
- Single point 120 volt power connection

Ruskin IAQ50X helps satisfy the requirements for minimum outside air as required by the following.

- ASHRAE 62.1, ASHRAE 90.1 and ASHRAE 189.1.
- California Title 24
- International Mechanical Code (IMC)
- International Energy Conservation Code (IECC)

VARIATIONS

Ruskin model IAQ50X is available with the following variations at additional cost.

- Stainless steel axle bearings
- Stainless steel linkage (includes axles, tie bars & control arms)
- * Flanged connection - front, rear, double or offset
- Internally mounted actuator (external mount is standard)
- Min./Max. units with CD50 for Economizer Operation

Notes:

1. Dimensions shown in () indicate millimeters.
2. Refer to installation manual for additional details.
3. Units furnished approximately 1/4" (6) smaller than given opening dimensions.
4. To order, send completed Order Process Sheet with purchase order.

DIMENSIONAL DETAILS

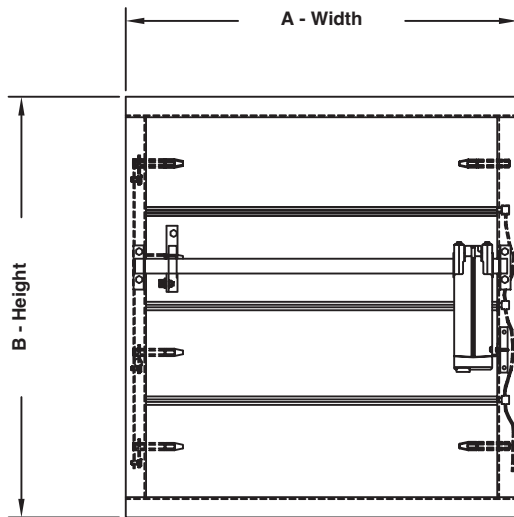

Face View (Internal Actuator Shown)

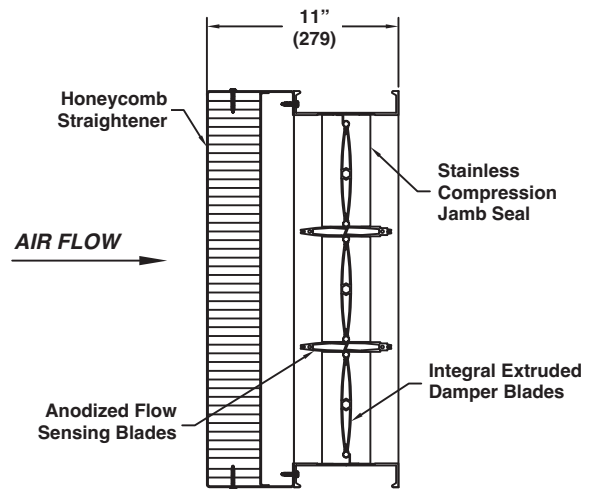

MOUNTING FLANGE OPTIONS

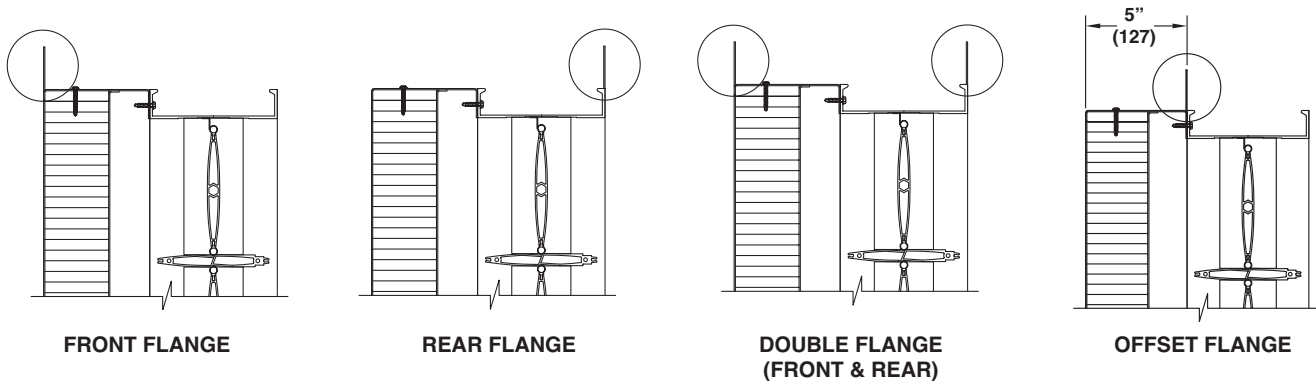

ACTUATOR MOUNTING OPTIONS

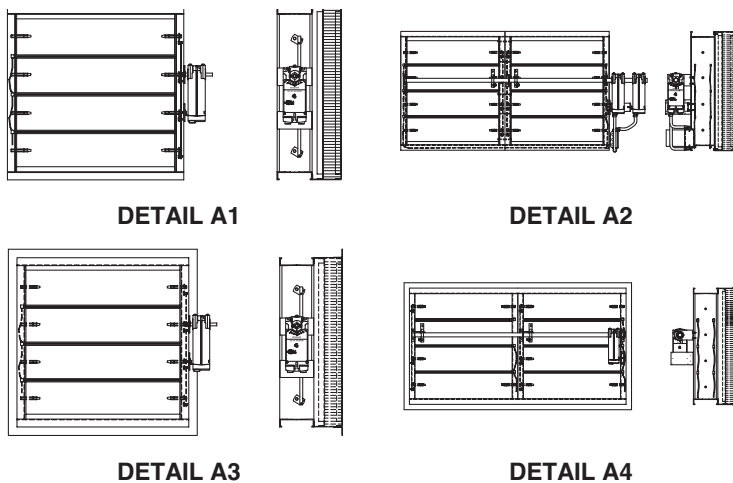

The details to the left show the standard arrangements for both internally mounted and externally mounted actuator options. Detail A1 shows the actuator externally mounted on a standard 6" damper output shaft. Any internally mounted actuator or multiple section assemblies require the use of a jackshaft. Detail A2 shows two actuators, externally mounted, on a jackshaft. When multiple actuators are used on the same jackshaft, they are factory wired in series. Detail A3 shows a standard single section assembly with an externally mounted actuator, while detail A4 shows a single actuator mounted internally on a multiple section assembly.

Note: Up to three actuators may be installed on a multiple section IAQ50X assembly. This limits a standard IAQ50X assembly to 56 square feet (consult the factory if your application exceeds actuator limitations).

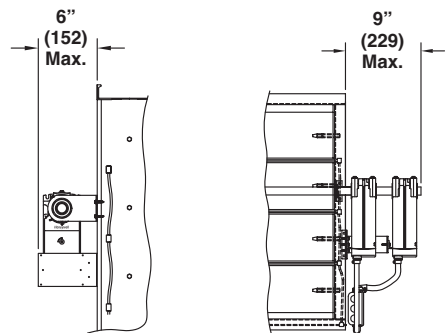

The envelope dimensions to the right are typical for all units with a B-Height dimension over 20" (508). On shorter units the actuator is rotated 90° to help keep the actuator within the overall frame dimension. Consult factory if your application requires a special actuator mounting arrangement.

IAQ50X MOUNTING CONFIGURATIONS

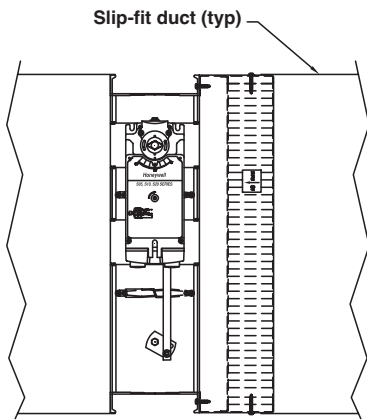

Full Configuration
(shown standard no flanges)

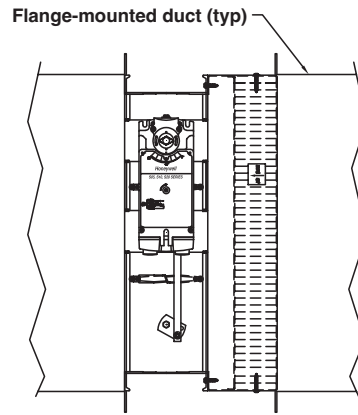

Full Configuration
(shown with double flange option)

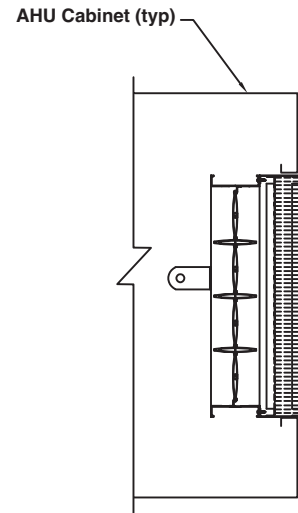

Full Configuration
(shown with front flange option)

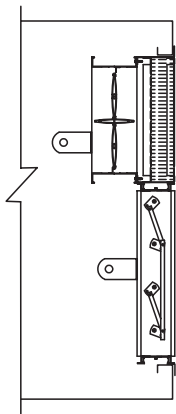

Top & Bottom Configuration
(shown with front flange option)

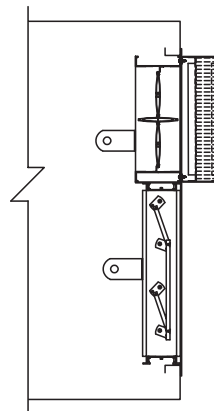

Top & Bottom Configuration
(shown with offset flange option)

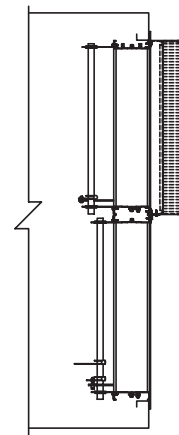

Side by Side Configuration
(shown with offset flange option)

There are three basic mounting configurations available on the Ruskin IAQ50X. All three are used in the same application - to measure and control the minimum outside air to ASHRAE Standard 62.1. Full configuration is typically used in duct runs or in wall openings. Other dampers may or may not be adjacent to the IAQ50X in this application. The other two mounting configurations are for minimum / maximum applications. Typically, the IAQ50X is

used to measure minimum until outside air conditions are suitable for "free cooling" (economizer mode). Once the "economizer" section is open it is not necessary to validate the minimum airflow measurement. The details above show some of the more common mounting configurations. For special configurations or to measure flow across both the minimum and maximum damper sections, consult the factory.

CONTROL WIRING & PIPING SCHEMATIC

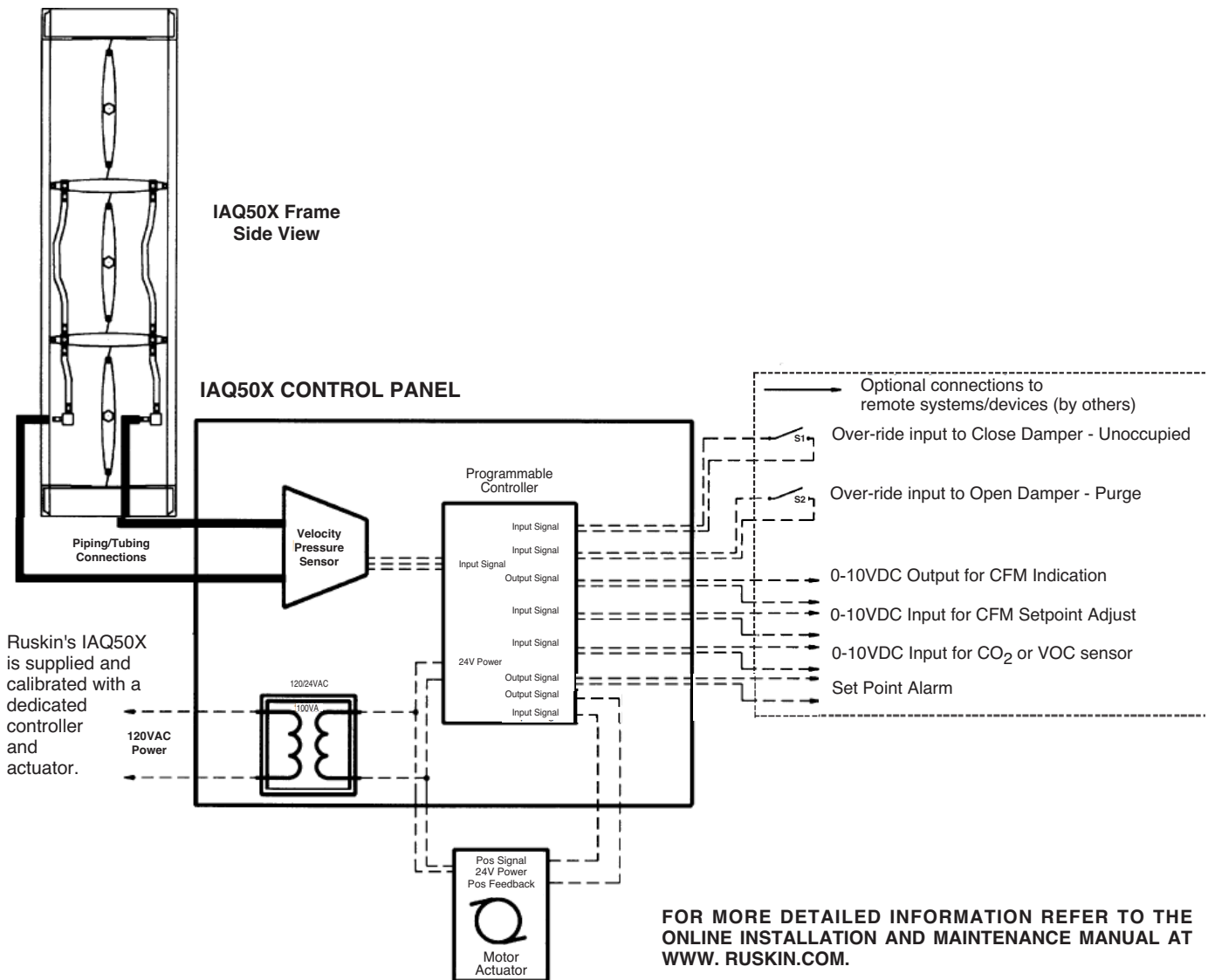

SUGGESTED SPECIFICATION

Furnish and install, at locations shown on plans or as in accordance with schedules, an air measuring station integral to an extruded aluminum outside air damper. The assembly shall meet AMCA class 1A leakage of 3 cfm per square foot at 1" water column. The complete air measuring device shall be factory assembled into one turnkey product and calibrated for the specific job requirements. Unit shall have a measuring range from 150 to 2,000 feet per minute and perform to airflow measurement and leakage criteria found in ASHRAE Standard 62, IBC and the IECC. The Air measuring station shall consist of 1/2" x 3" 3000 series aluminum alloy honeycomb, anodized 6063T6 high yield extruded aluminum sensing blades with built-in measuring ports and extruded aluminum airfoil control damper blades. The sensing blades shall remain stationary and shall be perpendicular to the flow at all times. All pressure tubing shall remain stationary and mounted outside of the air stream to reduce pressure drop. Tubing that is connected to moving parts is not acceptable. All sensor tubing shall terminate in

solid brass barbed fittings outside the air stream. The integral damper shall consist of 6063T6 high yield extruded aluminum blades. Blade edge seals shall be extruded TPR double edge design with inflatable pocket to enable air pressure to assist in seal-off and shall be mechanically locked in extruded blade slots. Adhesive or clip-on type seals are not acceptable. Axle bearings shall be non-corrosive molded synthetic and shall be molded to fit the hexagonal damper shaft to reduce leakage. Complete assembly shall be assembled, piped, wired and calibrated in an ISO 9001 certified facility. A factory furnished and calibrated controller shall be programmed, in nonvolatile EPROM, with the job specific CFM setpoint and range. The controller and actuator shall communicate to control to the desired CFM. The controller shall receive a 0-10 VDC input from the BAS and report a 0-10 VDC output that is proportional to the CFM. Air Measuring Stations shall be, in all respects, equivalent to Ruskin Model IAQ50X.



3900 Dr. Greaves Rd.
Kansas City, MO 64030
(816) 761-7476
FAX (816) 765-8955
www.ruskin.com