

# BTD830

## Bubble Tight Isolation Damper



### APPLICATION

Ruskin's single-bladed bubble tight damper model BTD830 is designed for rectangular/square flanged installations in which extreme low leakage is required. Typical applications include industrial process exhaust systems, laboratories, pharmaceutical facilities, nuclear power plants, DOE facilities, military facilities, and biotech labs. Each damper model BTD830 is factory tested prior to shipment for leakage performance in accordance with AMCA Standard 500-D.

### OPERATIONAL RATINGS

<b>Leakage Rating</b>	Bubble Tight per AMCA 500-D
<b>Maximum Velocity</b>	4000 FPM (20.3 m/s)
<b>Maximum Pressure</b>	10 in.wg. (2.5 kPa)
<b>Temperature Range</b>	-40°F to 250°F (-40°C to 121°C)

### DESIGN FEATURES

Description	Standard	Optional
<b>Frame</b>	Painted Steel Channel	304(L)SS, 316(L)SS
<b>Flanges</b>	Rectangular	Square Flanges
<b>Blade</b>	Painted Steel; Round Center-Pivoted	304(L)SS, 316(L)SS
<b>Axle</b>	304SS; Full Length	316SS, 316LSS
<b>Bearing</b>	304SS Sleeve Bolted to Exterior of Frame	
<b>Axle Seal</b>	Integral with Bearing Assembly	
<b>Blade Seal</b>	Silicone, Mechanically Fastened to the Blade	
<b>Finish</b>	Polyamide Epoxy	Mill 304(L)SS, 316(L)SS

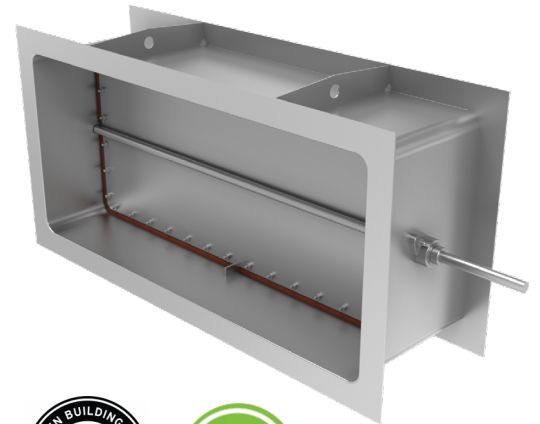

### DAMPER SIZES

<b>Minimum Size</b>	6 X 6 (152 X 152)
<b>Maximum Size</b>	36 X 16 (914 X 406)

### OPTIONS

- ▶ Mounting Hole Patterns in Flanges (None, Front, Back or both flanges)
- ▶ Factory-Supplied & Mounted Actuators and Limit Switches

### STANDARD CONSTRUCTION

Damper Height Inches (mm)		Frame & Flange Inches (mm)			Blade Thickness Gauge (mm)	Axle Diameter Inches (mm)
Above	Through	Flange Width 'F' Inches (mm)	Gauge (mm)	Frame Depth 'C' Inches (mm)		
≥ 6 (152)	8 (203)	2.0 (51)	12 (2.7)	8 (203)	12 (2.7)	0.75 (19)
8 (203)	12 (305)			10 (254)		
12 (305)	16 (406)			12 (305)		

# PRESSURE DROP INFORMATION

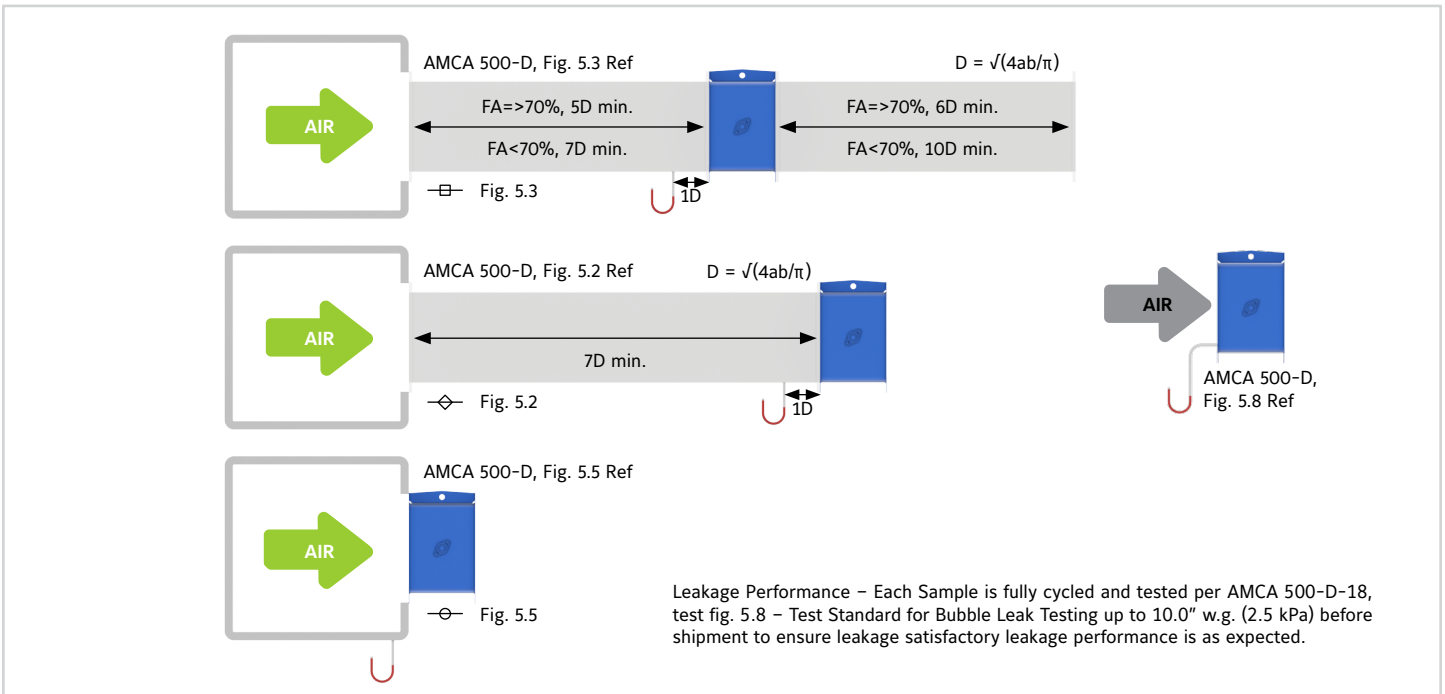

Performance Data - Sample tested per AMCA 500-D-18 Test Standard for Air Performance (Pressure Drop) for test figure: 5.5 (Bulkhead), 5.2 (Duct upstream) and 5.3 (Duct up amd downstream). Data Corrected to standard air density of 0.075 lbm/ft<sup>3</sup> (1.2 kg/m<sup>3</sup>)

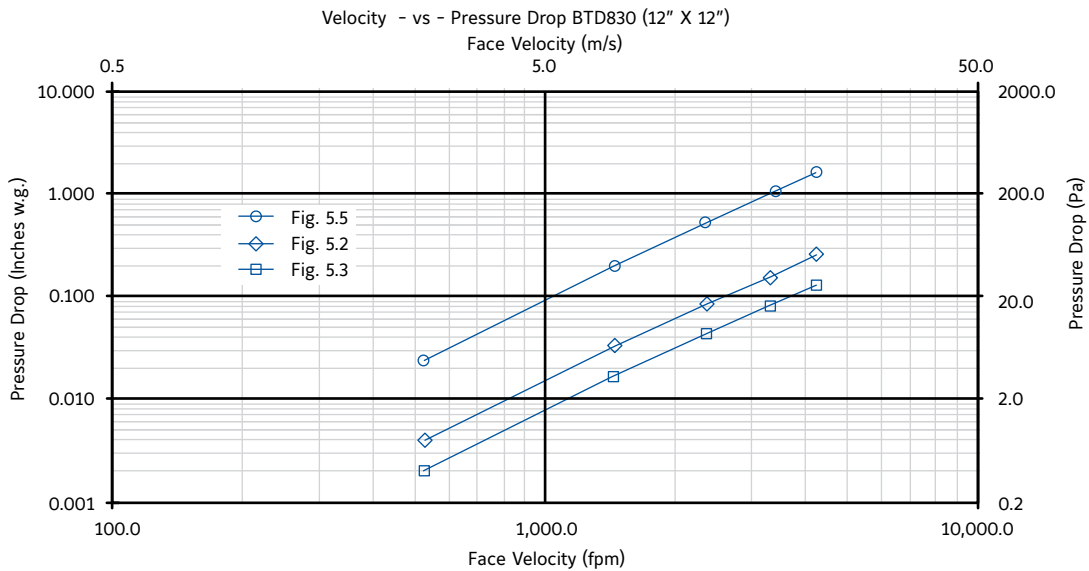

12" X 12" Fig. 5.5			
IP		SI Units	
V <sub>D</sub> (fpm)	Δ P <sub>D</sub> ("w.g.)	V <sub>D</sub> (m/s)	Δ P <sub>D</sub> (kPa)
522.1	0.024	2.7	6.0
1,450.6	0.201	7.4	50.1
2,377.6	0.529	12.1	131.8
3,307.5	1.013	16.8	252.3
4,232.9	1.644	21.5	409.5

12" X 12" Fig. 5.2	
V <sub>D</sub> (fpm)	Δ P <sub>D</sub> ("w.g.)
523.3	0.004
1,454.0	0.033
2,383.2	0.085
3,315.3	0.158
4,242.9	0.254

12" X 12" Fig. 5.3	
V <sub>D</sub> (fpm)	Δ P <sub>D</sub> ("w.g.)
521.9	0.002
1,450.1	0.017
2,376.7	0.044
3,306.2	0.083
4,231.2	0.132

## MOUNTING ORIENTATION

Damper to be installed with the axle in the horizontal plane

Vertical mount



Horizontal mount



## TYPICAL ACTUATOR MOUNTINGS (Optional)

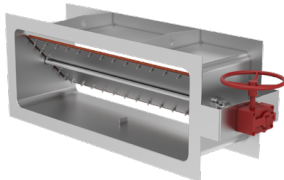

Manual Worm Gear  
with Hand Wheel

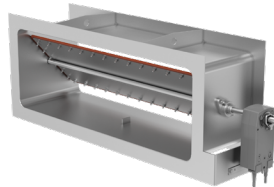

Direct-Mount  
Commercial Grade

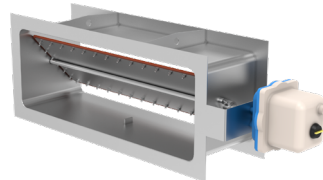

Electric  
Quarter-Turn Rotary

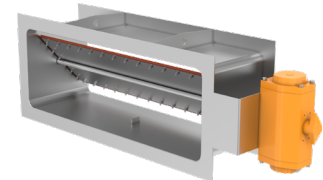

Pneumatic  
Quarter-Turn Rotary

## MOUNTING HOLE PATTERN INFORMATION

Bolt hole pattern data shown on this page is for square and rectangular flanged dampers that represents standard construction. When clearly specified, Ruskin can provide nonstandard hole dimensions and patterns to meet customer requirements.

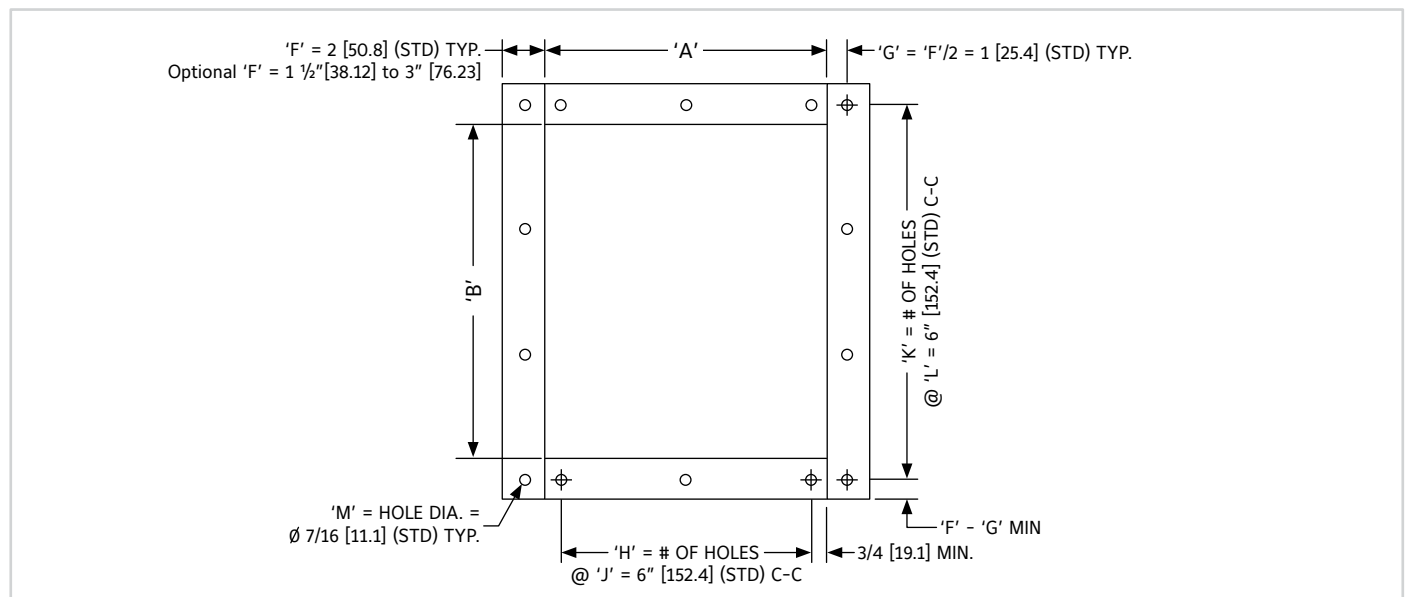

### NOTES:

- When H or K are one hole, locate hole on centerline.
- To calculate "H" & "K" on damper with standard construction (2" flanges):

$$"H" = \frac{A - 1.5}{6} \quad "K" = \frac{B + 2}{6}$$

Drop the decimal and add one (1) to determine number of holes. example .....

## SUGGESTED SPECIFICATION

Furnish and install, at locations shown on plans or in accordance with schedules, bubble tight dampers meeting the following specifications: Damper shall be manufactured in an ISO9001 certified factory. Dampers shall be butterfly type consisting of square or rectangular blade, welded to full length axle within the flanged frame. Frame shall have a clean, smooth interior surface. Double skin blade design shall be minimum 12ga (3.5) thick steel and be complete with solid silicone blade seal mechanically attached to blade and field replaceable.

Axle to be supported at each damper frame penetration by stainless steel sleeve bearings bolted to the damper frame and shall include axle seal integral to the bearing assembly.

Each damper shall be individually tested for leakage in accordance to AMCA standard 500-D Bubble Leak Method test figure 5.8 with the closed damper blade subjected to 10 in. w.g. (2.5 kPa) a bubble solution is used to detect leaks. Bubbles not to exceed more than 1/16" dia. bubbles after 1 second and 1/4" dia. bubbles after 1 minute under pressure. Submittal data shall include Pressure Drop information based on Test Figure 5.3, 5.2, and 5.5 set up.

Basis of design shall be Ruskin model BT830.

### LINKS TO IMPORTANT DOCUMENTS

Document Title
Limited Warranty Document



3900 Doctor Greaves Road  
Grandview, MO 64030  
Website: [www.ruskin.com](http://www.ruskin.com)  
Phone: (816) 761-7476