

AML6

Airflow Measuring Extruded Aluminum Stationary Louver



APPLICATION

Ruskin Model AML6 airflow measuring louver combines the functions of an outside air intake louver and an air measuring station in one compact assembly. Its 7" (178) nominal depth requires less installation space than separate louvers and air measurement devices. The patented AML6 features a wind-driven rain resistant vertical blade louver that allows high airflow with minimal water penetration and pressure drop. It is particularly well suited for applications in air handling units as well as air plenum wall installations. The AML6 has been tested to AMCA Standard 611-95.

STANDARD CONSTRUCTION

Frame	7" (177.8) deep, 6063T6 extruded aluminum with .125" (3.2) nominal wall thickness.
Blades	6063T6 extruded aluminum with .081" (2.1) nominal wall thickness. Blades are mounted vertically and spaced approximately 1 1/2" (38) center to center.
Sensor Blade	6063T6 extruded aluminum, clear anodize finish.
Sensor Port Fittings	Brass.
Pressure Transducer	RU-274-R2-VDC, 0-5 or 0-10 VDC output (field selectable), 0-1.0' wc (250 Pa) Range. Output signal is proportional to CFM (l/s).
Accuracy	3% Deviation Average Across Measurement Range.
Power Requirements	24 VAC or VDC ±10%.
Output Signal	0-5 or 0-10 VDC output (field selectable).
Extended Sill	.081" (2.1) formed aluminum with end dams.
Finish	Mill.
Operating Temperature	-22°F to +140°F (-30°C to +60°C) standard.
Minimum Size	12" w x 12" h (305 x 305).
Maximum Size	Shall be 48" x 96" (1219 x 2438). Lifting lugs provided on louvers 48" x 48" (1219 x 1219) and larger. Louvers larger than the maximum factory assembly size will require field assembly of smaller sections.
Approximate Shipping Weight	12 lbs. per sq. ft. (58.6 kg/m ²).
Velocity Requirements	Minimum 345 FPM (1.75 m/s) Free Area Velocity. Maximum 2,175 FPM (11.05 m/s) Free Area Velocity.

Consult Ruskin for additional information.

*Unit furnished 1/4" (6) smaller than given opening dimensions.

FEATURES

- ▶ .01" w.g. (2.49 Pa) pressure reading occurs at 345 fpm (105 mpm) free area velocity.
- ▶ Pressure test chart provided with each individual louver.
- ▶ Closely spaced vertical blades prevent the penetration of wind-driven rain.
- ▶ Published free area and pressure drop performance ratings based on testing in accordance with AMCA Publication 511.
- ▶ Aluminum construction for low maintenance and high resistance to corrosion.

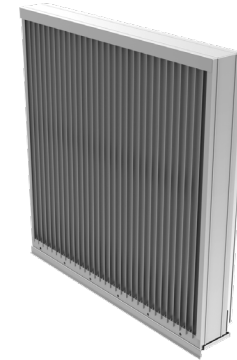

Ruskin AML6 helps satisfy the requirements for minimum outside air as required by the following.

- ▶ ASHRAE 62.1, ASHRAE 90.1 and ASHRAE 189.1.
- ▶ California Title 24.
- ▶ International Mechanical Code (IMC).
- ▶ International Energy Conservation Code (IECC).

VARIATIONS

- ▶ Damper Controller available with factory calibration.
- ▶ Ruskin Control Dampers may be installed 3" (76) behind sensing blades. Dampers may be provided with electric or manual actuators.
- ▶ Optional finishes available at additional cost. Please see [Paint Finishes and Color Guide](#) and [Finish Type Model Chart](#) for more details. Contact louversales@ruskin.com with questions
- ▶ **Additional Transducer Model Options:** AMS8100, AMS8100LR, DPT-IQ

NOTES:

- Consult Ruskin for other special requirements.
- Dimensions in parenthesis () indicate millimeters.

FREE AREA GUIDE

Free Area Guide shows free area in ft² and m² for various sizes of AML6.

Width – Inches and Meters

	12 0.30	18 0.45	24 0.60	30 0.75	36 0.90	42 1.05	48 1.20
12 0.30	0.09 0.01	0.16 0.02	0.23 0.02	0.31 0.03	0.38 0.04	0.45 0.04	0.52 0.05
18 0.45	0.27 0.03	0.49 0.05	0.70 0.07	0.92 0.09	1.14 0.11	1.35 0.13	1.57 0.15
24 0.60	0.45 0.04	0.81 0.08	1.17 0.11	1.53 0.14	1.89 0.18	2.26 0.21	2.62 0.24
30 0.75	0.63 0.06	1.14 0.11	1.64 0.15	2.15 0.20	2.65 0.25	3.16 0.29	3.66 0.34
36 0.90	0.81 0.08	1.46 0.14	2.11 0.20	2.76 0.26	3.41 0.32	4.06 0.38	4.71 0.44
42 1.05	0.99 0.09	1.79 0.17	2.58 0.24	3.37 0.31	4.17 0.39	4.96 0.46	5.76 0.54
48 1.20	1.17 0.11	2.11 0.20	3.05 0.28	3.99 0.37	4.93 0.46	5.86 0.55	6.80 0.63
54 1.35	1.35 0.13	2.44 0.23	3.52 0.33	4.60 0.43	5.68 0.53	6.77 0.63	7.85 0.73
60 1.50	1.53 0.14	2.76 0.26	3.99 0.37	5.21 0.48	6.44 0.60	7.67 0.71	8.89 0.83
66 1.65	1.71 0.16	3.09 0.29	4.46 0.41	5.83 0.54	7.20 0.67	8.57 0.80	9.94 0.92
72 1.80	1.89 0.18	3.41 0.32	4.93 0.46	6.44 0.60	7.96 0.74	9.47 0.88	10.99 1.02
78 1.95	2.07 0.19	3.73 0.35	5.39 0.50	7.05 0.66	8.71 0.81	10.37 0.96	12.03 1.12
84 2.10	2.26 0.21	4.06 0.38	5.86 0.55	7.67 0.71	9.47 0.88	11.28 1.05	13.08 1.22
90 2.25	2.44 0.23	4.38 0.41	6.33 0.59	8.28 0.77	10.23 0.95	12.18 1.13	14.13 1.31
96 2.40	2.62 0.24	4.71 0.44	6.80 0.63	8.89 0.83	10.99 1.02	13.08 1.22	15.17 1.41

Height – Inches and Meters

PRESSURE DROP

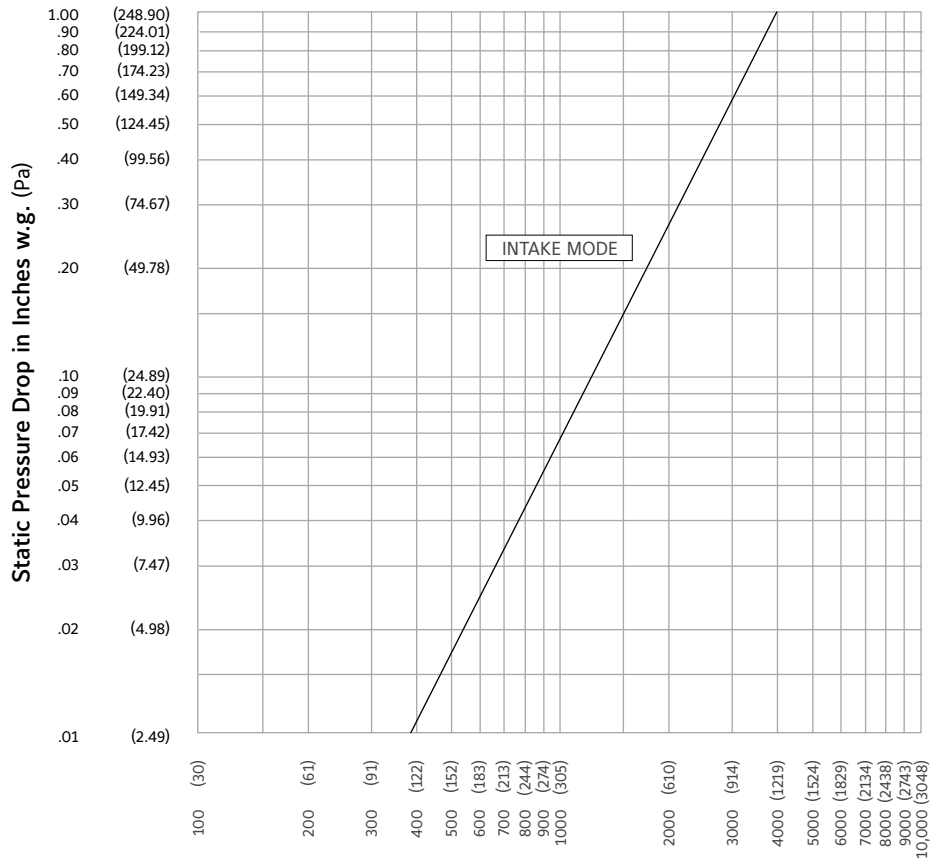

Air Velocity in feet (meters) per minute through Free Area

NOTE: Ratings are based on AMCA Standard 610 Test Setup Figures 1 & 2.
Ratings do not include the effect of a bird screen.

WIND-DRIVEN RAIN PERFORMANCE – AMCA 500-L WIND-DRIVEN RAIN TEST

Test size is 1m x 1m (39" x 39") core area, 1.05m x 1.08m (41 1/4" x 42 5/16") nominal. Free Area of test louver is 4.86 ft² (.45m²).

Wind Velocity mph (kph)	Rainfall Rate In./hr. (mm/hr.)	Core Velocity ₁ FPM (m/s)	Airflow cfm (m ³ /min)	Free Area Velocity ₂ fpm (m/sec.)	Effectiveness Ratio	Class _{3,4}	Discharge Loss Class ₅ Intake
29 (46.4)	3 (76)	970 (5)	10,444 (295)	2,149 (10.9)	99.9%	A	2
50 (80.5)	8 (203)	982 (5)	10,570 (298)	2,175 (11.0)	99.8%	A	2

NOTES:

1. Core area is the open area of the louver face (face area less louver frames). Core Velocity is the airflow velocity through the Core Area of the louver (1m x 1m). 5 m/s is the maximum core velocity utilized in this test.

2. Free Area of test size is calculated per AMCA standard 500-L.

3. Wind-Driven Rain Penetration Classes:

Class	Effectiveness
A	1 to .99
B	0.989 to 0.95
C	0.949 to 0.80
D	Below 0.8

4. The AML6 provides class A performance at all velocities up to and including 5 m/s core velocity.

5. Discharge Loss Coefficient is calculated by dividing a louvers' actual airflow rate vs. a theoretical airflow for the opening. It provides an indication of the louver's airflow characteristics.

Class	Discharge Loss Coefficient
1	0.4 and above
2	0.3 to 0.399
3	0.2 to 0.299
4	0.199 and below

(The higher the coefficient, the less resistance to airflow.)

6. The AMCA Wind Driven Rain Test is performed in a laboratory environment and incorporates controlled wind, water and system airflow effects. In actual field installations, storms may create conditions not considered by the AMCA test. Penthouse and similar applications where wind can pass through multiple louvers in an enclosure is another condition that is not simulated by AMCA tests. These applications can create elevated water penetration rates through any louver. Because of these uncontrolled situations it is recommended that provisions to manage water penetration through louvers be included in the building design.



Ruskin Company certifies that the Louver shown herein is licensed to bear the AMCA Seal. The ratings shown are based on tests and procedures performed in accordance with AMCA Publication 511 and comply with the requirements of the AMCA Certified Ratings Program. The AMCA Certified Ratings Seal applies to air performance ratings and wind driven rain ratings only.

OPERATION

The AML6 Airflow Measuring Louver provides airflow information which can be utilized to maintain desired outside air intake volumes through a wide range of HVAC system settings. The airflow measuring blades are positioned vertically behind the louver blades at a specific center to center spacing and measure air velocity pressure. Air tubing/piping connections carry the velocity pressure from the sensing blades to a factory supplied pressure transducer. The pressure transducer converts the velocity pressure to an output signal proportional to CFM (l/s).

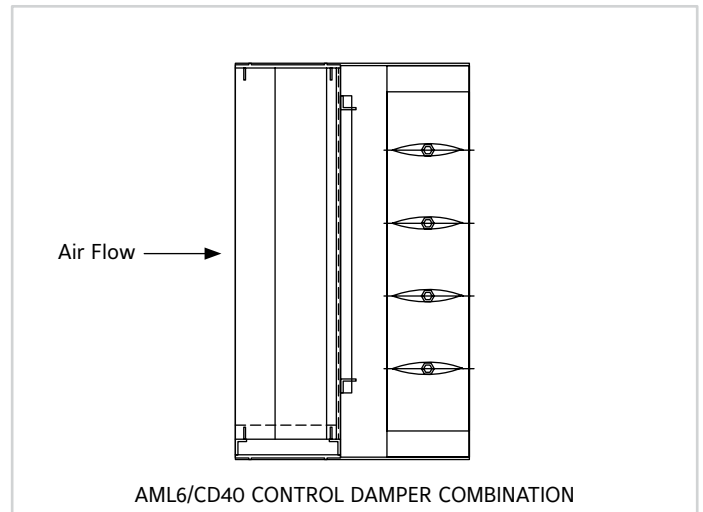
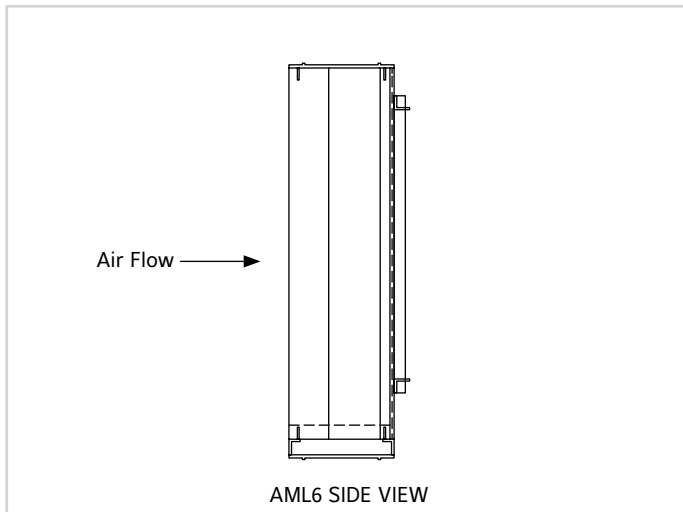

FRAME CONSTRUCTION

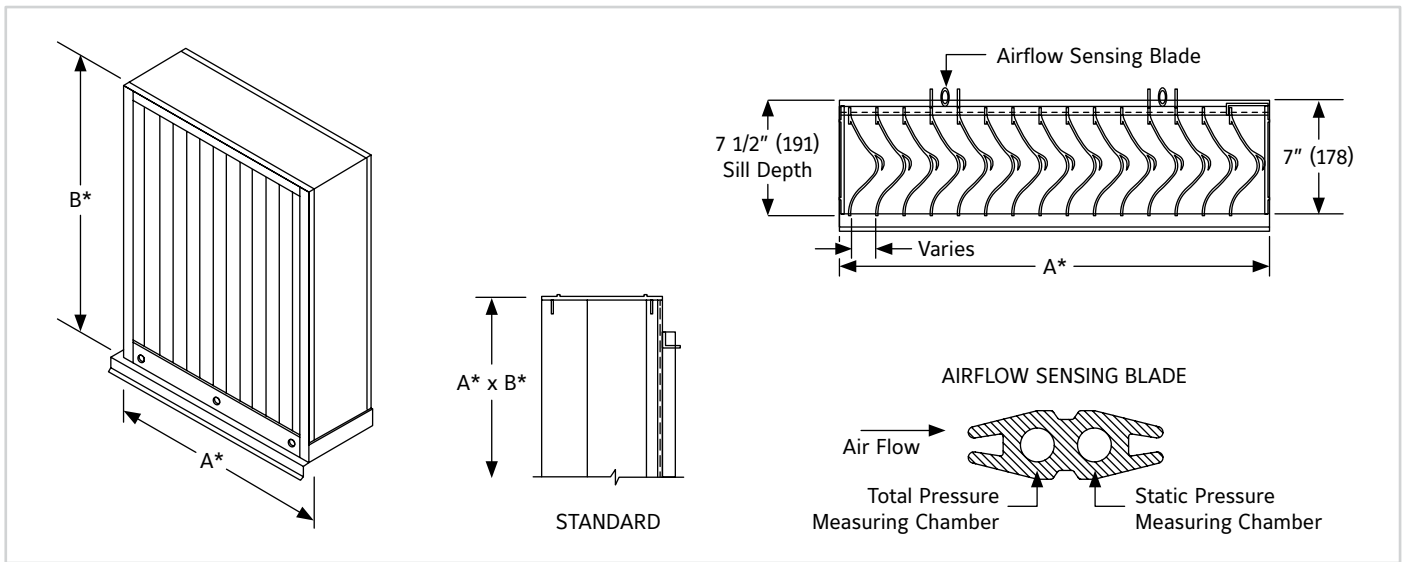

SUGGESTED SPECIFICATION

Furnish and install louvers as hereinafter specified where shown on plans or as described in schedules. Louvers shall possess stationary vertical blades designed to prevent the penetration of wind driven rain. Louver blades shall be contained within a 6" (152) frame. Louver components (heads, jamba, sill and blades) shall be factory assembled by the louver manufacturer. Louvers shall be provided with Ruskin Pressure Transducer conforming to EMC standards EN50082-1/EN5014/EN60730-1. Transducer to be capable of reading pressures as low as ± 0.05 " wc (± 12.5 pa) and shall handle up to 10 PSID overpressure without zero shift. Transducer output to be field selectable 0-5 VDC/0-10 VDC. Transducer shall incorporate glass-on-silicone (Gi-Si) capacitance sensor and shall be housed in a NEMA 4 enclosure. Louver sizes too large for shipping shall be build up by the contractor from factory assembled louver sections to provide overall sizes required. Louver design shall limit single section sizes to 48" x 72" (1219 x 1829) and shall withstand a wind load of 30 lbs per sq. ft. (1.44 kPa) (equivalent of a 110 mph wind [177 kph] - specifier may substitute any loading required).

Complete assembly shall be constructed, piped and calibrated in an ISO 9001 certified facility.

Louver shall be Ruskin Model AML6 extruded 6063T6 aluminum alloy construction as follows:

Frame: 7" (177.8) wall thickness, caulking surfaces provided.

Blades: .081" (2.1) wall thickness, installed vertically on approximately 1.5" (38) centers.

Finish: Select finish specification from Ruskin Finishes Brochure.

i LINKS TO IMPORTANT DOCUMENTS

Document Title
Paint Finishes and Color Guide
Limited Warranty Document



3900 Doctor Greaves Road
Grandview, MO 64030
Website: www.ruskin.com
Phone: (816) 761-7476