

DTS-SD

Operation Instruction Supplement

Damper Test Switch For Smoke Dampers



APPLICATION

The Damper Test Switch for Smoke Dampers (DTS-SD) is an optional “momentary” push button test switch available on Ruskin smoke dampers. The DTS-SD gives maintenance personnel the ability to “cycle test” the smoke damper by pushing and holding the button until the damper cycles to its de-energized position. The DTS-SD may be supplied factory mounted and wired to the dampers actuators or shipped loose for field wiring.

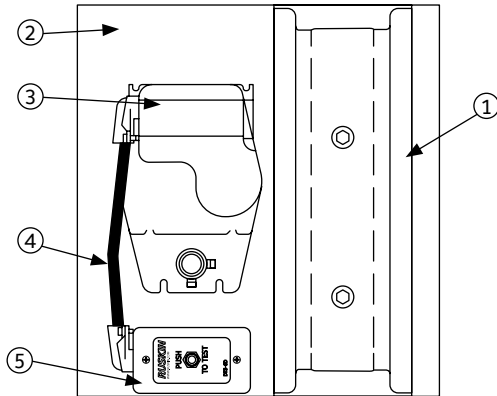

SEE COMPLETE MARKING ON PRODUCT

ITEM	DESCRIPTION
1	Smoke Damper
2	Side Plate or Sleeve
3	Actuator
4	Conduit
5	DTS-SD

Pneumatic actuators to be piped per local codes.
 Electric actuators to be wired per the National Electric Code (NEC) and local codes. See actuator for wiring diagrams.

WIRING DIAGRAM

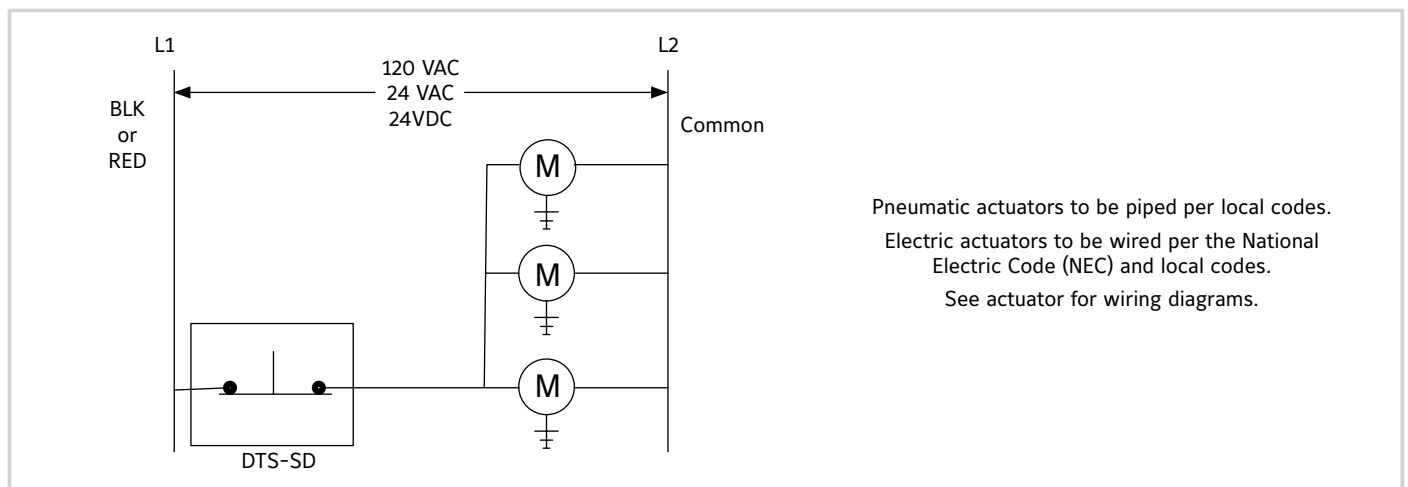

Pneumatic actuators to be piped per local codes.
 Electric actuators to be wired per the National Electric Code (NEC) and local codes.
 See actuator for wiring diagrams.

LINKS TO IMPORTANT DOCUMENTS

Document Title
Limited Warranty Document



3900 Doctor Greaves Road
 Grandview, MO 64030
 Website: www.ruskin.com
 Phone: (816) 761-7476