

FSAFB24-SR-S**Fire & Smoke, Fail-Safe, Spring Return, Modulating 2-10 VDC Actuators****Technical Data**

Power Supply	24 VAC \pm 20%, 24 VDC -10% + 20%
Power Consumption Running	6 W, 8.5 VA
Power Consumption Holding	3 W, 5 VA
Transformer Sizing	10 VA (class 2 power source 24 VAC only)
Shaft Diameter	1/2" to 1.05" round, centers on 1/2" and 3/4" with insert, 1.05" without insert
Electrical Connection	(2) 3 ft, 18 GA appliance cables with 1/2" conduit connectors
Overload Protection	electronic throughout 0° to 95° rotation
Electrical Protection	actuators are double insulated
Operating Range Y	2 to 10 VDC, 4 to 20 mA (w/ 500 Ω , 1/2 W resistor) ZG-R01
Input Impedance	100 k Ω for 2 to 10 VDC (0.1 mA), 500 Ω for 4 to 20 mA
Feedback Output U	2 to 10 VDC, 0.5 mA max
Angle of Rotation	95° (adjustable with mechanical end stop, 35° to 95°)
Torque (US unit)	180 in-lbs [20 Nm] minimum
Direction of Rotation (Motor)	can be selected by CCW/CW mounting
Direction of Rotation (Fail-Safe)	can be selected by CCW/CW mounting
Position Indication	visual indicator, 0° to 95° (0° is full spring return position)
Manual Override	5 mm hex crank (3/16" Allen), supplied
Running Time (Motor)	75 sec
Running Time (Fail-Safe)	<20 sec
Humidity	5 to 95% RH non-condensing
Ambient Temperature Range	-22°F to 122°F [-30°C to 50°C]
Storage Temperature Range	-40°F to 176°F [-40°C to 80°C]
Housing	NEMA 2, IP54, UL enclosure type 2
Housing Material	zinc coated metal and plastic casing
Gears	steel, permanently lubricated
Agency Listings†	CE, UL 60730-1, CSA C22.2 No. 139 certified Listed to UL 2043 - suitable for use in air plenums per Section 300.22(C) of the NEC and Section 602 of the IMC
Noise Level (Motor)	Inaudible holding, running <40 dB (A) spring <62 dB (A)
Servicing	maintenance free
Quality Standard	ISO 9001
Weight	4.9 lb. [2.25 kg]
Auxiliary Switch	2 x SPDT, 3A resistive (0.5A inductive) @ 250 VAC, one set at +10°, one adjustable 10° to 90°

Torque min. 180 in-lb, Control 2 to 10 VDC, Feedback 2 to 10 VDC**Application**

For proportional control of fire and smoke combination and smoke dampers in UL555S applications. In new installations, UL 555S requires that actuators be mounted by the damper manufacturer.

Operation

The FSAFB24-SR & FSAFB24-SR-S actuators provide 95° of rotation and are provided with a graduated position indicator showing 0° to 95°. A unique manual override allows the setting of any actuator position within its 95° of rotation with no power applied. This mechanism can be released physically by the use of a crank supplied with the actuator. When power is applied the manual override is released and the actuator drives toward the fail-safe position to synchronize before going to the position commanded by the signal.

The actuator uses a brushless DC motor which is controlled by an Application Specific Integrated Circuit (ASIC). The ASIC monitors and controls the brushless DC motor's rotation and provides a Digital Rotation Sensing (DRS) function to prevent damage to the actuator in a stall condition. The position feedback signal is generated by a feedback potentiometer. The actuator may be stalled anywhere in its normal rotation without the need of mechanical end switches. The actuator cannot burn out from being stalled before full rotation is achieved.

The FSAFB24-SR, FSAFB24-SR-S, is mounted directly to control shafts up to 1.05" diameter by means of its universal clamp and anti-rotation bracket. A crank arm and several mounting brackets are available for damper applications where the actuator cannot be direct coupled to the damper shaft. The spring return system provides the specified torque to the application during a power interruption. The FSAFB24-SR, FSAFB24-SR-S, actuator is shipped at +5° (5° from full fail-safe) to provide automatic compression against damper gaskets for tight shut-off.

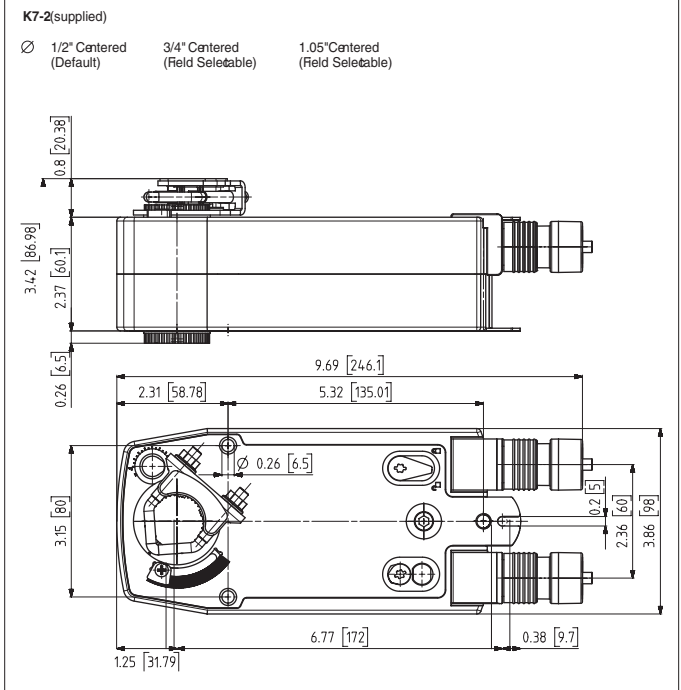
Dimensions (Inches[mm])

Accessories	
AF-P	Anti-rotation bracket AF/NF.
IND-AFB	AFB(X)/NFB(X) position indicator.
K7-2	Standard AFB(X)/NFB(X) clamp (1/2" to 1.05").
KG8	Ball joint for 5/16" diameter rod, 90°, galvanized steel.
KH-AFB	AFB(X)/NFB(X) crankarm (with 3/4" dia. shaft pass through).
SH8	Push rod for KG6 & KG8 ball joints (36" L, 5/16" diameter).
TOOL-06	8 mm and 10 mm wrench.
ZG-100	Univ. right angle bracket (17" H x 11-1/8" W x 6" base).
ZG-101	Univ. right angle bracket (13" H x 11" W x 7-7/16" base).
ZG-118	AFB(X)/NFB(X) U bracket (5-7/8" H x 5-1/2" W x 2-19/32" D).
ZG-AFB	AFB(X)/NFB(X) crankarm adaptor kit.
ZG-AFB118	AFB(X)/NFB(X) crankarm adaptor kit.
ZG-DC1	Damper clip for damper blade, 3.5" width.
ZG-DC2	Damper clip for damper blade, 6" width.
ZS-100	Weather shield - galvanneal (13" L x 8" W x 6" D).
ZS-150	Weather shield - PC w/ foam seal (16" L x 8-3/8" W x 4" D).
ZS-260	Explosion proof housing.
ZS-300	NEMA 4X, 304 stainless steel enclosure.
BAE165 US	165° F electric thermal sensor, SPST, normally closed.
SGA24	Positioner control for modulating actuators (surface mount).
S2A-F US	Auxiliary switch, 2x SPDT, 3A (0.5A inductive) @250 VAC max.

Wiring Diagrams

APPLICATION NOTES

- ◆ Meets cULus requirements without the need of an electrical ground connection.
- 1 Provide overload protection and disconnect as required.
- 3 Actuators may also be powered by 24 VDC.
- 45 Actuators may be powered in parallel. Power consumption must be observed.
- 72 S4 makes to S6 when actuator is powered open.
- 73 Auxiliary switches are for end position indication or interlock control.
- 74 Double insulated.
- 78 500 ohm load resistor for 4-20 mA. Only one resistor for multiple actuators.
- 79 Master-slave control/wiring of mechanically paralleled ("piggyback") Fire and Smoke actuators will not function.
- 80 Actuators may be electrically paralleled on different damper sections that are not mechanically connected to one another.
- 81 Smoke relay and primary heat responsive sensor may be located in hot wire.
- 82 Only one smoke signal and/or thermal sensor may be employed for all paralleled actuators.
- 83 Any wire 5 feedback could be used to indicate position or to drive actuators that are not mechanically paralleled. That is, they are on other dampers.

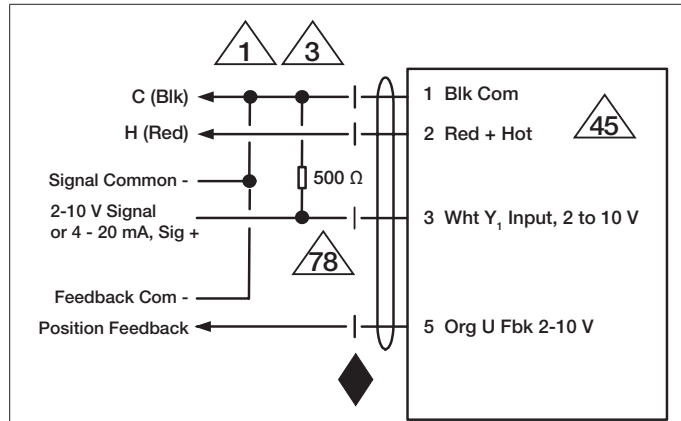

24 VAC/DC

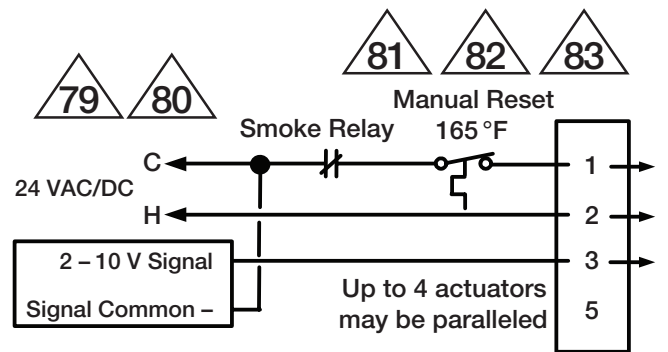

Parallel wiring

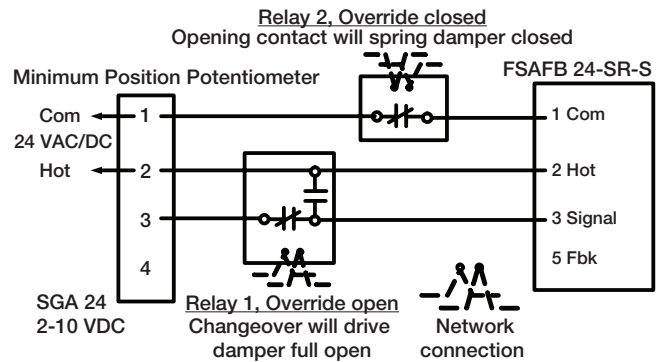

FSAFB24-SR used as a balancing actuator, FSAF24-BAL

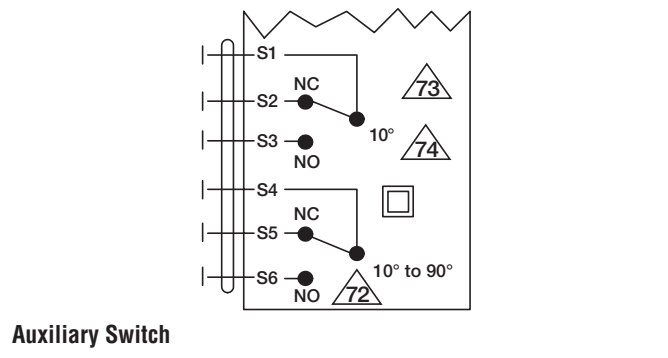

Auxiliary Switch