

# GENERIC ACOUSTICAL LOUVERS

## Installation Guide



### LIST OF MODELS AFFECTED

MODELS AFFECTED	
ACL445	ACL1245
ACL645	ACL1245AF
ACL845	EAL6811
ACL845AF	

For enquiries, Please contact Louver Sales: [louversales@ruskin.com](mailto:louversales@ruskin.com)

### PRE-ASSEMBLY INSTRUCTIONS:

1. Remove louvers accessories from shipping crates inspect for damage. Single section units will be shipped fully assembled. Multi-section units will be shipped in shipping sections to be assembled at the job site. Large multi section units may be packaged in more than one shipping crate.
2. Care must be taken when handling components. Lift louver sections carefully by the supports or frames. Avoid lifting by louver blades. Do not apply excessive force to any point of the section. Lift at multiple points, if necessary to avoid deformation or racking of components.
3. Inspect louvers components after removal from crates. Verify that all components fasteners are accounted for. Report any shortages immediately to Ruskin manufacturing.
4. Inspect the openings that the louvers will be installed in. verify that the openings are square and that the unit will fit prior to installation. Check available installation depth for possible HVBS interference. If HVBS must be notched or modified for installation, secure the HVBS to a suitable substrate as close to the modification as possible to maintain structural integrity.
5. Contact your local Ruskin representative if you have questions pertaining to this installation or other field modifications.
6. Ensure that you have received ship loose parts & a box with hardware. (varies based on what is ordered).

### ASSEMBLY PROCEDURE:

1. Install extended sill in the opening (if ordered).
2. Locate ship loose hardware required for louver multi-section assembly.
3. Position the louver sections faced down on a level, non-abrasive surface in the configuration they will be assembled in. Reference the tag numbers on each section to ensure the sections are in correct order.
4. Refer to appropriate exploded details for splice hardware identification & location. Now fasten the sections together at frames, support splices. (Supports are pre-drilled at plant for ease).
5. If perimeter clips or continuous angles are to be installed (ordered), locate anchor them in the opening.(Reference clip angle installation guide for instructions).
6. Level the louver assembly both horizontally and vertically in the opening using shims. (Shims not provided by Ruskin).
7. Position the louver in the opening so that the desired sealant joint will be maintained around the perimeter of louver.
8. After louver is secured, install backer rod sealant around louver perimeter. (Sealant not provided by Ruskin).

## REFERENCE IMAGES

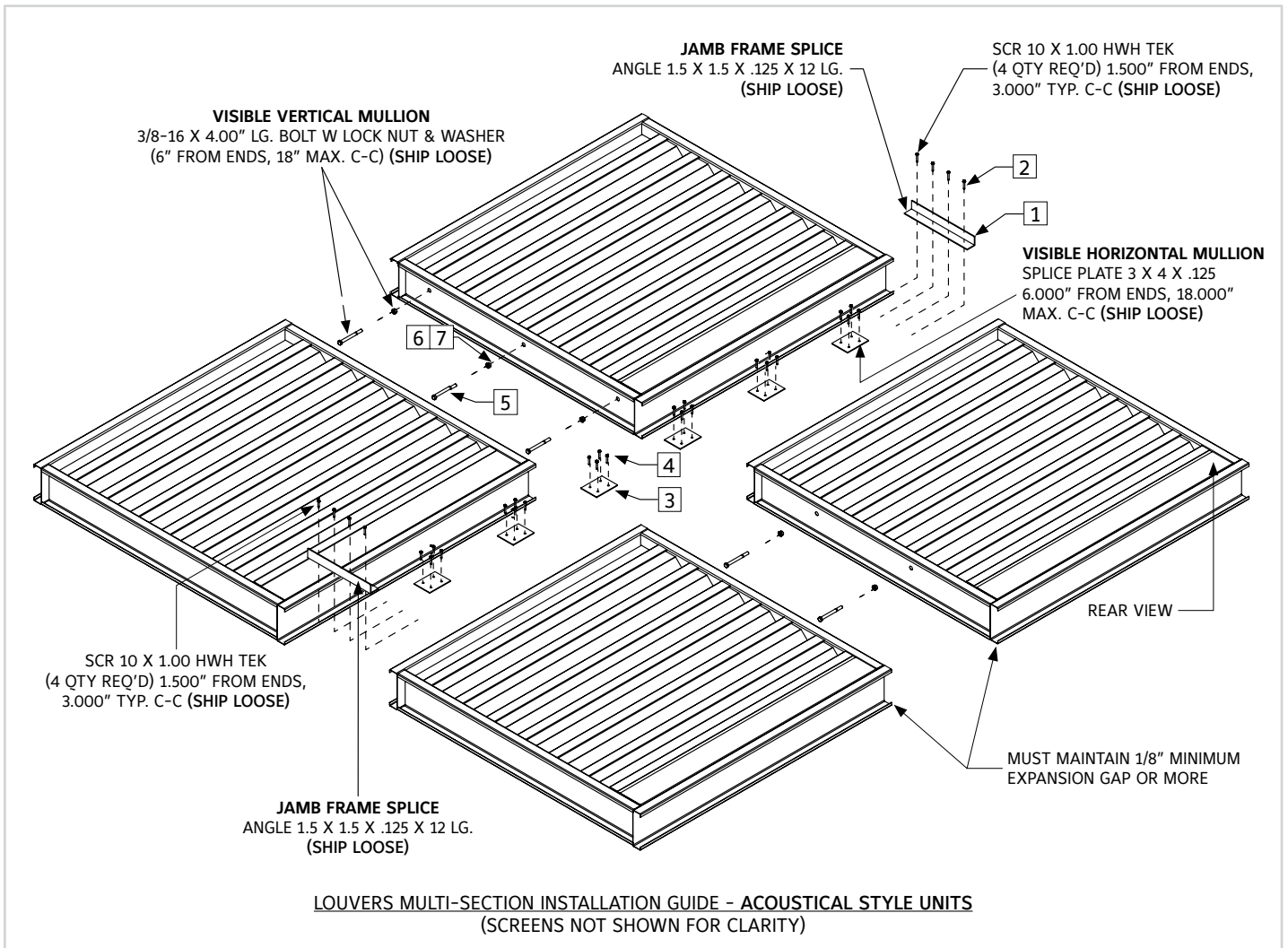

ITEM #	DESCRIPTION	QTY.	PART #	MATERIAL
<b>PARTS LIST TABLE - JAMB FRAME SPLICE (SHIP LOOSE)</b>				
1	ANGLE 1.5 X 1.5 X .125 X 12 LG.	1	360437300	EXT ALUM 6063-T5 .125" THK
2	SCR 10 X 1.00 HWH TEK	4	380430941	410/ZC
<b>PARTS LIST TABLE - VISIBLE HORZ. MULLION (SHIP LOOSE)</b>				
3	SPL PLT ACL 3 X 4	1	360502813 /360502814 /360502815	12GA GALV/ .125 THK ALUM /12GA 304SST
4	SCR 10 X 1.25 HWH TEK	4	380431060	410/ZC
<b>PARTS LIST TABLE - VISIBLE VERTICAL MULLION (SHIP LOOSE)</b>				
5	BLT 3/8-16X4.00 HHD	1	380431493	ZC
6	NUT NYLOCK 3/8-16	1	380430951	ZC
7	WSH FLAT 3/8 USS	1	38026500	ZC

# 1X2 MULTI SECTION EXPLODED VIEW

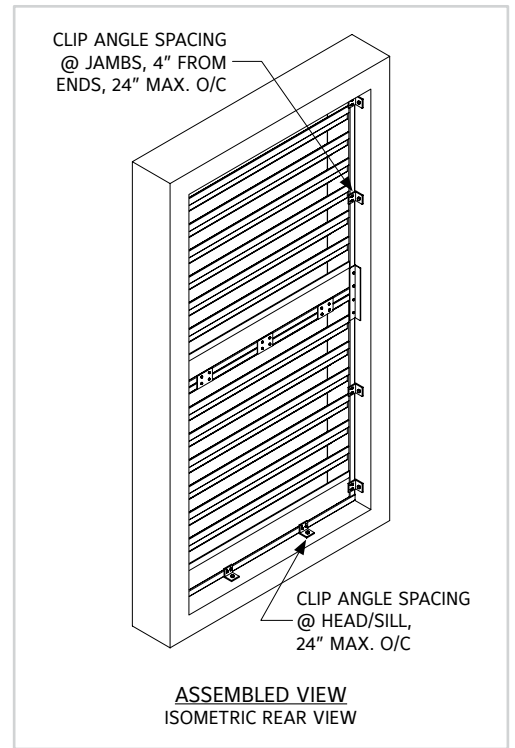
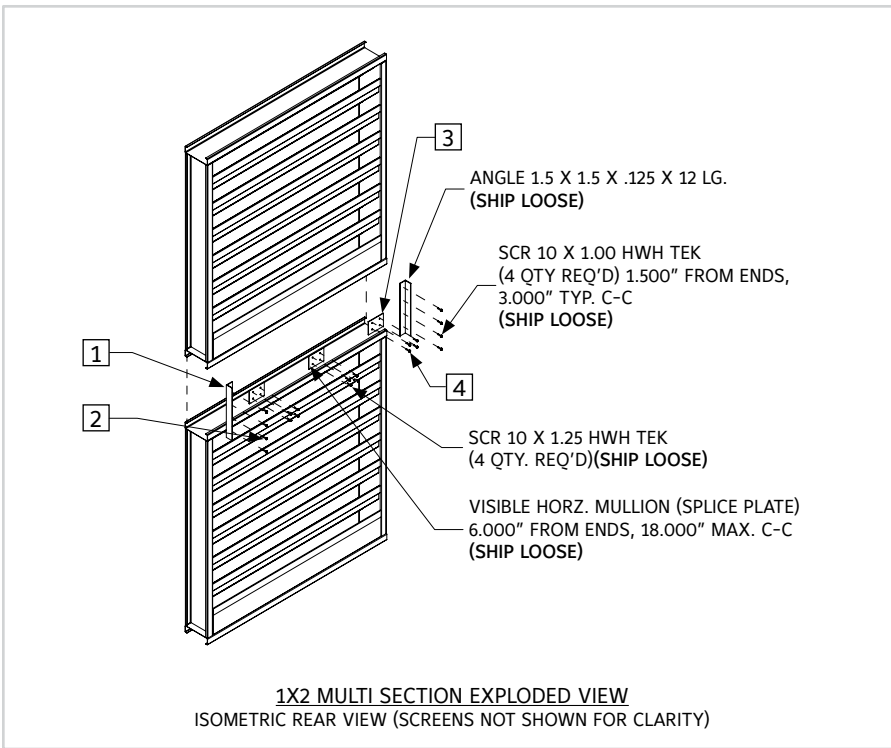

ITEM #	DESCRIPTION	QTY.	PART #	MATERIAL
<b>PARTS LIST TABLE - 1X2 MULTI SECTION (SHIP LOOSE)</b>				
1	ANGLE 1.5 X 1.5 X .125 X 12 LG.	1	360437300	EXT ALUM 6063-T5 .125" THK
2	SCR 10 X 1.00 HWH TEK	4	380430941	410/ZC
3	SPL PLT ACL 3 X 4	1	360502813/ 360502814/ 360502815	12GA GALV/ .125 THK ALUM/ 12GA 304SST
4	SCR 10 X 1.25 HWH TEK	4	380431060	410/ZC

\*\* Attachments varies per louver

## 2X1 MULTI SECTION EXPLODED VIEW

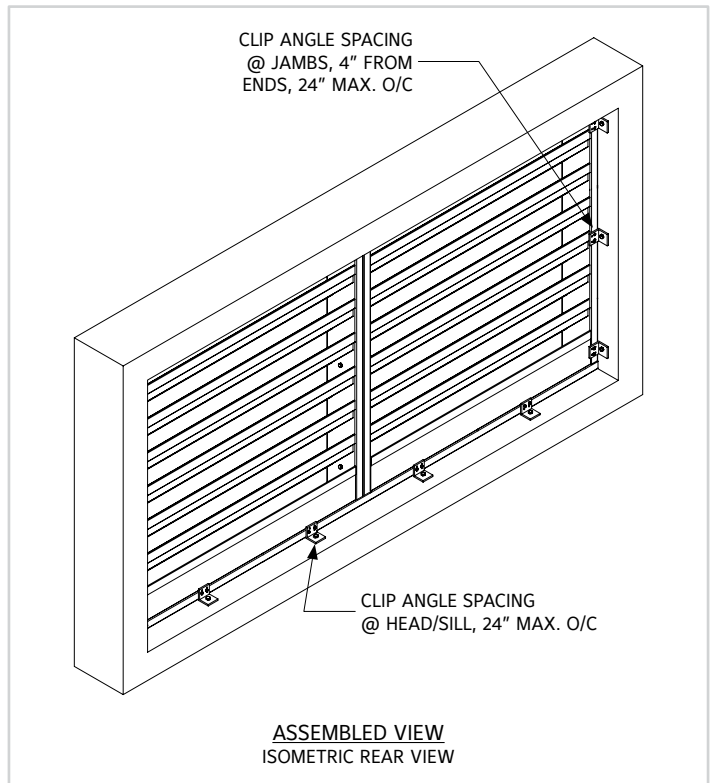
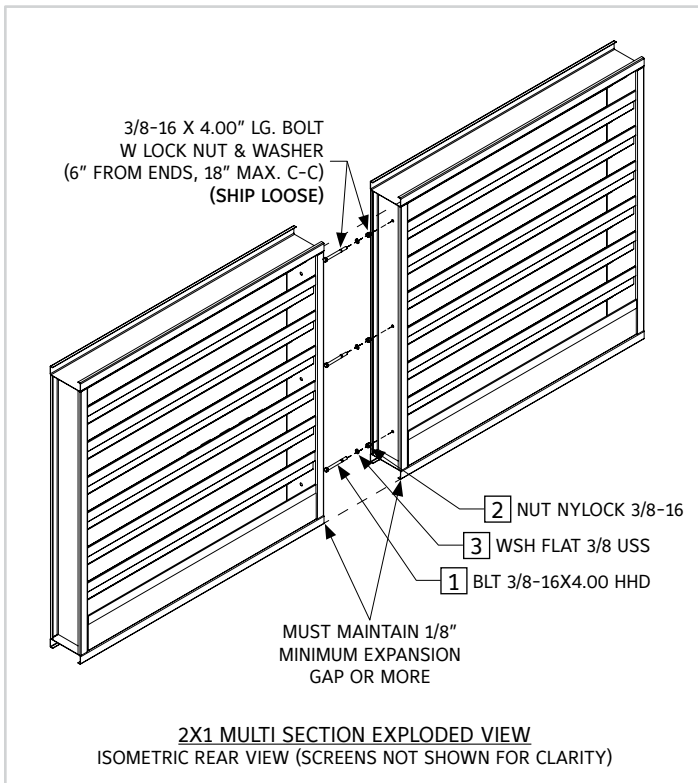

ITEM #	DESCRIPTION	QTY.	PART #	MATERIAL
<b>PARTS LIST TABLE - 2X1 MULTI SECTION (SHIP LOOSE)</b>				
1	BLT 3/8-16 X 4.00 HHD	1	380431493	ZC
2	NUT NYLOCK 3/8-16	1	380430951	ZC
3	WSH FLAT 3/8 USS	1	38026500	ZC

\*\* Attachments varies per louver  
 \*\* Square balloons refer ship loose parts

## MULTI SECTION LOUVER ASSEMBLY

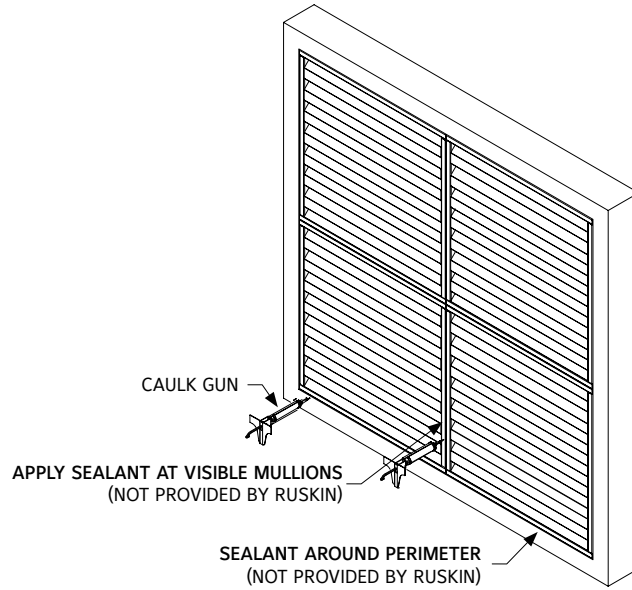

**MULTI SECTION LOUVER ASSEMBLY**  
ISOMETRIC FRONT VIEW (SEALANT / CAULK INFORMATION)

### **i** LINKS TO IMPORTANT DOCUMENTS

Document Title
Limited Warranty Document



3900 Doctor Greaves Road  
Grandview, MO 64030  
Website: [www.ruskin.com](http://www.ruskin.com)  
Phone: (816) 761-7476