

GENERIC ARCHITECTURAL STYLE

Installation Guide



LIST OF MODELS AFFECTED

MODELS AFFECTED	
ELF15J	ELF6811S
ELF211	ELF811SH
ELF375X	ELF81S30
ELF375XH	ELF837
ELF6375X	EME720
ELF6375XH	EME737
ELF6425DD	EME745
ELF6811	

For enquiries, Please contact Louver Sales: louversales@ruskin.com

PRE-ASSEMBLY INSTRUCTIONS:

1. Remove louvers accessories from shipping crates inspect for damage. Single section units will be shipped fully assembled. Multi-section units will be shipped in shipping sections to be assembled at the job site. Large multi section units may be packaged in more than one shipping crate.
2. Care must be taken when handling components. Lift louver sections carefully by the supports or frames. Avoid lifting by louver blades. Do not apply excessive force to any point of the section. Lift at multiple points, if necessary to avoid deformation or racking of components.
3. Inspect louvers components after removal from crates. Verify that all components fasteners are accounted for. Report any shortages immediately to Ruskin manufacturing.
4. Inspect the openings that the louvers will be installed in. Verify that the openings are square & that the unit will fit prior to installation. Check available installation depth for possible HVBS interference. If HVBS must be notched or modified for installation, secure the HVBS to a suitable substrate as close to the modification as possible to maintain structural integrity.
5. Contact your local Ruskin representative if you have questions pertaining to this installation or other field modifications.
6. Ensure that you have received ship loose parts a box with hardware. (varies based on what is ordered).

ASSEMBLY PROCEDURE:

1. Install extended sill in the opening (if applicable).
2. Locate ship loose hardware required for louver multi-section assembly.
3. Position the louver sections faced down on a level, non-abrasive surface in the configuration they will be assembled in. Reference the tag numbers on each section to ensure the sections are in correct order.
4. Refer to appropriate exploded details for splice hardware identification location. Now fasten the sections together at frames, support splices. (Supports are pre-drilled at plant for ease).
5. If perimeter clips or continuous angles are to be installed, locate anchor them in the opening. (Reference clip angle installation guide for instructions).
6. Level the louver assembly both horizontally and vertically in the opening using shims. (Shims not provided by Ruskin).
7. Position the louver in the opening so that the desired sealant joint will be maintained around the perimeter of louver.
8. On architectural style units, check blade alignment at the vertical joints. Loosen section connecting hardware adjust the position of the sections as required to achieve good blade-to-blade alignment. When alignment is complete, tighten all section connecting hardware.
9. After louver is secured, install backer rod sealant around louver perimeter. Refer sheet 2 for sealant information. (Sealant not provided by Ruskin).

REFERENCE IMAGES

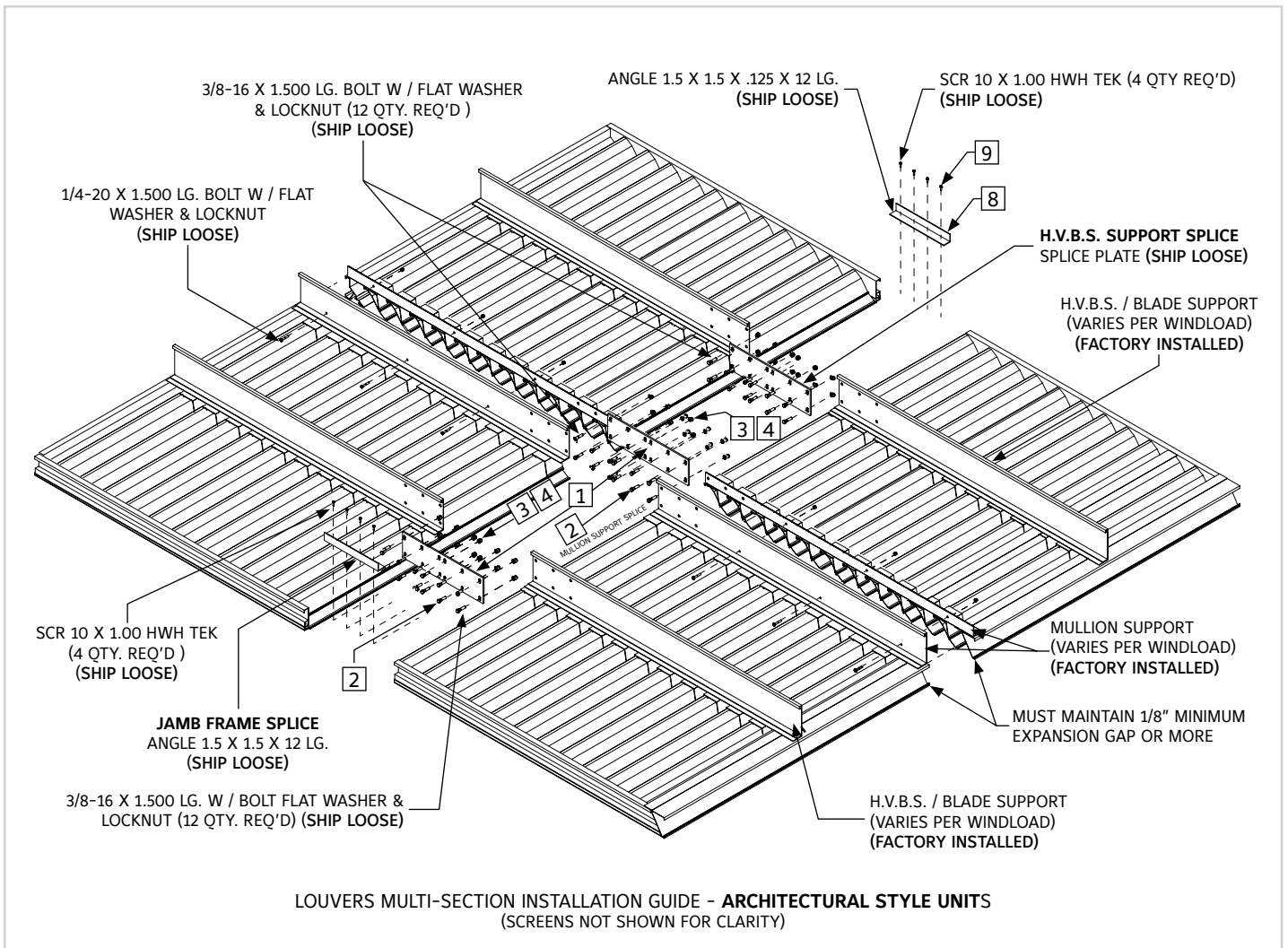

ITEM #	DESCRIPTION	QTY.	PART #	MATERIAL
PARTS LIST TABLE - H.V.B.S. & MULLION SUPPORT SPLICE (SHIP LOOSE)				
1	SPL PLT HDG 5 X 18 X 1/4	1	360500786	HOT DIPPED GALVANIZED
2	BLT 3/8-16 X 1.50 HHD	12	38006800	ZC
3	NUT NYLOCK 3/8-16	12	380430951	ZC
4	WSH FLAT 3/8 USS	12	38026500	ZC
5	BLT 1/4-20 X 1.50 HHD	VARIES	38008500	ZC
6	WSH FLAT 1/4 USS	VARIES	38026300	ZC
7	NUT NYLOCK 1/4-20	VARIES	38009500	ZC
PARTS LIST TABLE - JAMB FRAME SPLICE (SHIP LOOSE)				
8	ANGLE 1.5 X 1.5 X .125 X 12 LG.	1	360437300	EXT ALUM 6063-T6
9	SCR 10 X 1.00 HWH TEK	4	380430941	410/ZC

** Square balloons indicates ship loose parts

1X2 MULTI SECTION LOUVER INSTALLATION

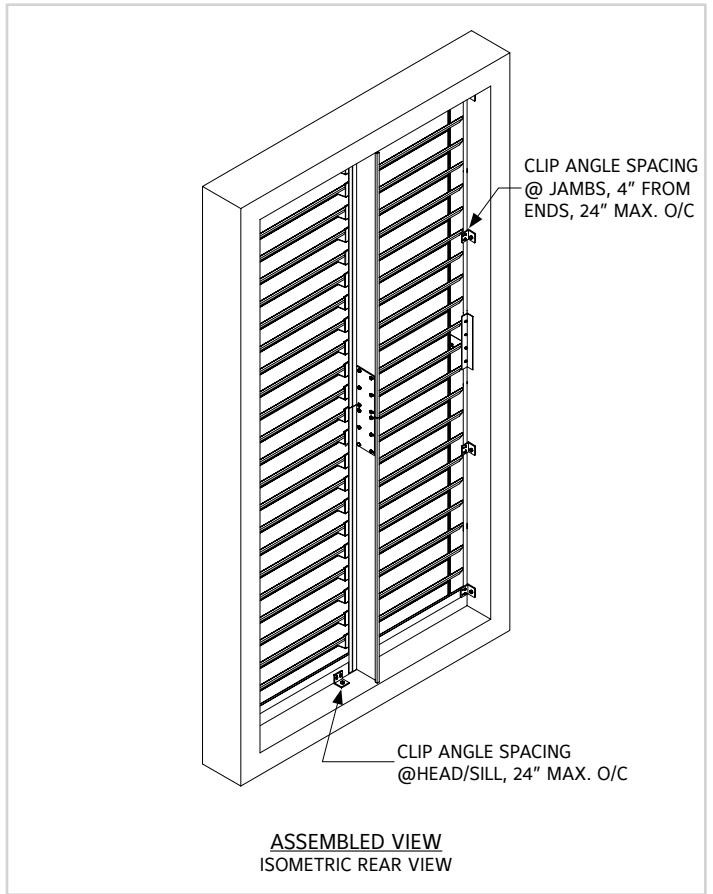
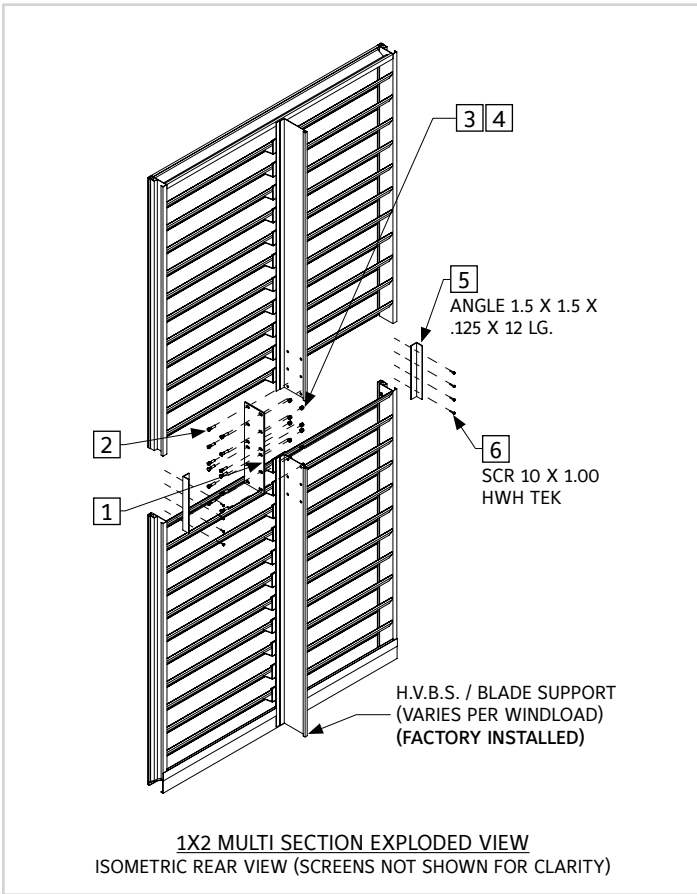

ITEM #	DESCRIPTION	QTY.	PART #	MATERIAL
PARTS LIST TABLE - 1X2 MULTI SECTION (SHIP LOOSE)				
1	SPL PLT HDG 5 X 18 X 1/4	1	360500786	HOT DIPPED GALVANIZED
2	BLT 3/8-16 X 1.50 HHD	12	38006800	ZC
3	WSH FLAT 3/8 USS	12	38026500	ZC
4	NUT NYLOCK 3/8-16	12	380430951	ZC
5	ANGLE 1.5 X 1.5 X .125 X 12 LG.	2	360437300	EXT ALUM 6063-T6
6	SCR 10 X 1.00 HWH TEK	8	380430941	410/ZC

** Attachments varies per louver windload

2X1 MULTI SECTION LOUVER INSTALLATION

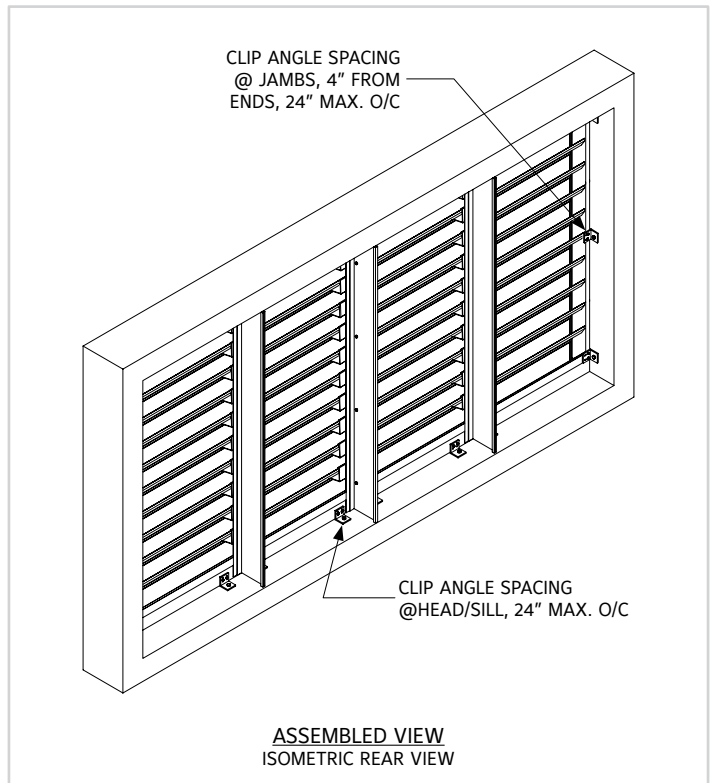
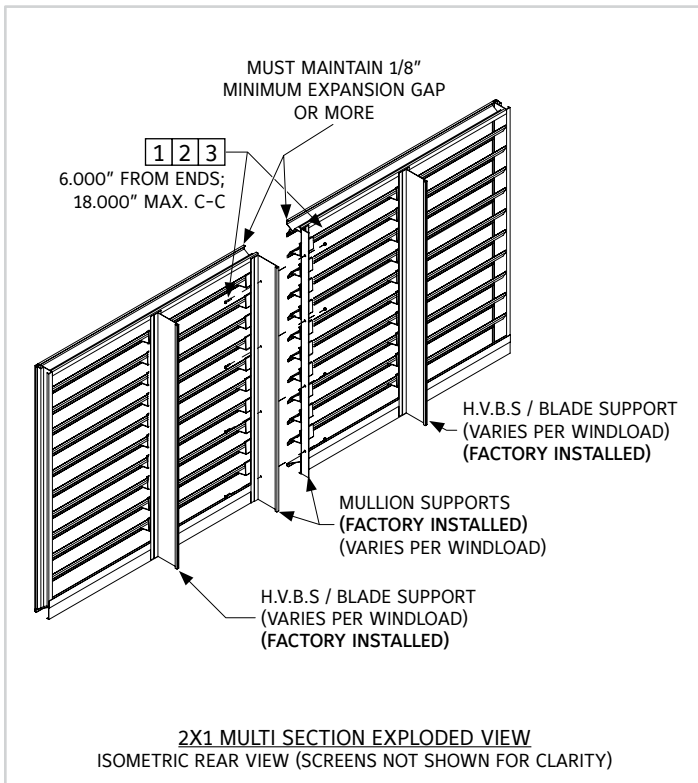

ITEM #	DESCRIPTION	QTY.	PART #	MATERIAL
PARTS LIST TABLE - 2X1 MULTI SECTION (SHIP LOOSE)				
1	BLT 1/4-20 X 1.000 HHD	VARIES	38007500	ZC
2	NUT NYLOCK 1/4-20	VARIES	38009500	ZC
3	WSH FLAT 1/4 USS	VARIES	38026300	ZC

** Attachments varies per louver windload
** Square balloons indicates ship loose parts

REFERENCE IMAGES

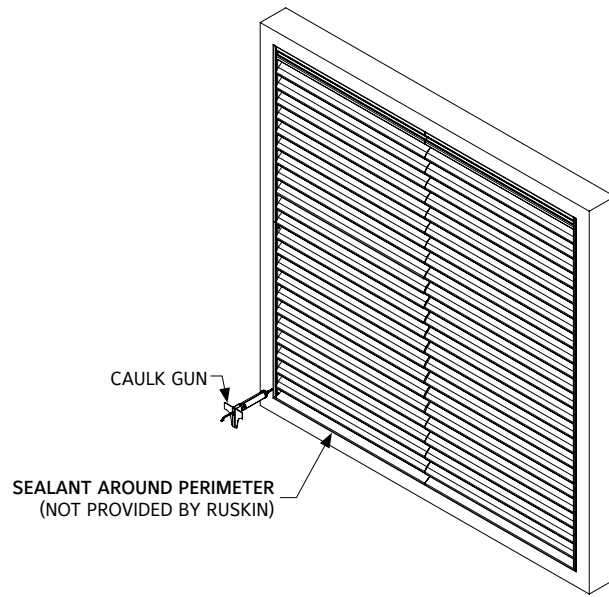

MULTI SECTION LOUVER ASSEMBLY
ISOMETRIC FRONT VIEW (SEALANT / CAULK INFORMATION)

i LINKS TO IMPORTANT DOCUMENTS

Document Title
Limited Warranty Document



3900 Doctor Greaves Road
Grandview, MO 64030
Website: www.ruskin.com
Phone: (816) 761-7476