

TED50GS (GENSET)

Thermally Efficient Extruded Aluminum Insulated Airfoil Blade Damper
AMCA Class IA Leakage Rated



APPLICATION

The TED50GS is designed to provide maximum combustion air and pressure relief quickly for emergency generator start up to avoid damage of equipment or surrounding space. The factory mounted fast-acting 8-second spring open actuator provides optimal performance and reliability. The TED50GS also provides AMCA class 1A leakage rating of 3cfm/ft² at 1" w.g. when blades are closed to meet requirements of the International Energy Conservation Code (IECC).

STANDARD CONSTRUCTION

Frame	5" x 1" x .125" (127 x 25 x 3.2) 6063-T6 extruded aluminum.
Blades	5/64" (2) 6063-T6 extruded aluminum airfoil insulated. Parallel blade action.
Blade Seals	Santoprene™ TPV type, mechanically fastened.
Jamb Seals	Ribbed Santoprene™.
Bearings	Dual action Polycarbonate with Copolymer Acetal sleeve.
Axles	7/16" (11) hexagonal plated steel.
Linkage	Plated steel, Concealed out of airstream.
Control Shaft	1/2" (13) dia. x 6" long plated steel for single section. 1" (25) dia. jackshaft for multi-section assemblies.
Actuator	RUS-L-GEN Series with NEMA 4X enclosure. 24 VAC/VDC or 120 VAC (with or without built-in auxiliary switches). Damper operation is power close / spring-return open.

PERFORMANCE RATINGS

Leakage	AMCA Class IA (see page 3).
Velocity	Up to 4000 fpm (20.3 m/s).
Pressure	Up to 6 in. w.g. (1.5 kPa).
Temperature	-45°F to +185°F (-43°C to +85°C).
Torque	7 in-lb/ft ² .
Airflow	Both directions.
R Value	2.16 (tested to ASTM C1363-2011).

OPTIONS & ACCESSORIES

Frame	Broke, Front flange, rear or both sides with or without bolt holes.
Sleeve/ Transition	Factory installed, with or without transitions.
Switches	SP100 blade (open/closed) switch package.
Bearings, Linkage & Axles	Stainless steel
Blade & Jamb Seals	Silicone
Finish	Clear Anodized



FEATURES

- ▶ AMCA Class IA Leakage Rated
- ▶ Special fast acting 8 second spring-return actuator tested to 40,000 cycles
- ▶ Insulated airfoil blade, low pressure drop
- ▶ Twin seals isolate blade thermal break
- ▶ R Value = 2.16 (tested to ASTM C1363-2011)

DIMENSIONS & WEIGHT

Minimum Size	12" x 12 3/4" (305 x 324)	
Maximum	Section:	48" x 72" (1219 x 1829)
	Assembly:	Unlimited
Weight:	5.5 lbs./ft ² (2.5 kg)	

Note: Dimensions shown in parenthesis () indicate millimeters.

AIR PERFORMANCE DATA

TED50GS air performance testing is performed in accordance with AMCA Standard 500-D configurations 5.2, 5.3 and 5.5 as illustrated below. All data has been corrected to standard air density of .075 lb/ft³ (1.201 kg/m³).

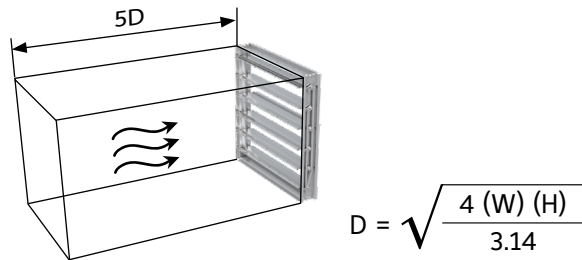

AMCA Figure 5.2 was established to represent a ducted damper that is exhausting into an open area. In this configuration entrance losses are minimized by a straight duct run upstream of the damper.

Air Performance Data—AMCA Test Figure 5.2									
12 x 12 (305 x 305)		24 x 24 (610 x 610)		36 x 36 (914 x 914)		12 x 48 (305 x 1219)		48 x 12 (1219 x 305)	
Velocity	Pressure Drop	Velocity	Pressure Drop	Velocity	Pressure Drop	Velocity	Pressure Drop	Velocity	Pressure Drop
FPM	in. WG	FPM	in. WG	FPM	in. WG	FPM	in. WG	FPM	in. WG
500	0.09	500	0.03	500	0.02	500	0.03	500	0.05
1000	0.38	1000	0.11	1000	0.08	1000	0.13	1000	0.21
1500	0.85	1500	0.25	1500	0.18	1500	0.30	1500	0.47
2000	1.50	2000	0.44	2000	0.33	2000	0.52	2000	0.83
2500	2.35	2500	0.69	2500	0.51	2500	0.82	2500	1.30
3000	3.41	3000	1.00	3000	0.74	3000	1.18	3000	1.87
3500	4.64	3500	1.36	3500	1.02	3500	1.60	3500	2.51
4000	6.06	4000	1.78	4000	1.33	4000	2.09	4000	3.28

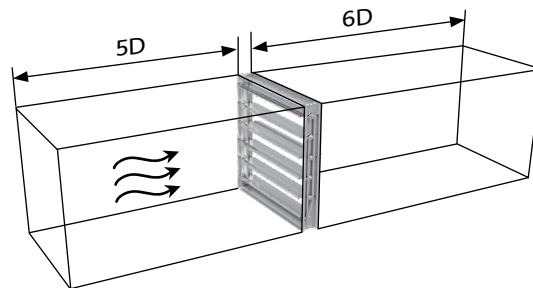

AMCA Figure 5.3 was established to represent a fully ducted damper with straight duct upstream and downstream. With entrance and exit losses minimized by this straight duct arrangement, this configuration has the lowest pressure drop of all three configurations.

Air Performance Data—AMCA Test Figure 5.3									
12 x 12 (305 x 305)		24 x 24 (610 x 610)		36 x 36 (914 x 914)		12 x 48 (305 x 1219)		48 x 12 (1219 x 305)	
Velocity	Pressure Drop	Velocity	Pressure Drop	Velocity	Pressure Drop	Velocity	Pressure Drop	Velocity	Pressure Drop
FPM	in. WG	FPM	in. WG	FPM	in. WG	FPM	in. WG	FPM	in. WG
500	0.06	500	0.01	500	0.01	500	0.02	500	0.03
1000	0.24	1000	0.06	1000	0.03	1000	0.08	1000	0.10
1500	0.54	1500	0.13	1500	0.08	1500	0.16	1500	0.24
2000	0.97	2000	0.22	2000	0.13	2000	0.28	2000	0.41
2500	1.51	2500	0.34	2500	0.20	2500	0.44	2500	0.54
3000	2.18	3000	0.49	3000	0.29	3000	0.62	3000	0.93
3500	2.96	3500	0.65	3500	0.39	3500	0.84	3500	1.27
4000	3.86	4000	0.86	4000	0.51	4000	1.07	4000	1.65

AIR PERFORMANCE DATA

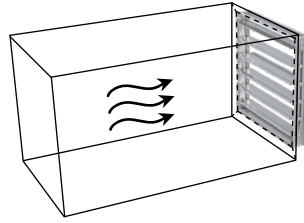

AMCA Figure 5.5 was established to represent a damper installed on a plenum wall. Sudden area changes entering and exiting the damper create extreme losses, making this the highest pressure drop of the three configurations tested.

Air Performance Data—AMCA Test Figure 5.5									
12 x 12 (305 x 305)		24 x 24 (610 x 610)		36 x 36 (914 x 914)		12 x 48 (305 x 1219)		48 x 12 (1219 x 305)	
Velocity	Pressure Drop	Velocity	Pressure Drop	Velocity	Pressure Drop	Velocity	Pressure Drop	Velocity	Pressure Drop
FPM	in. WG	FPM	in. WG	FPM	in. WG	FPM	in. WG	FPM	in. WG
500	0.11	500	0.05	500	0.05	500	0.05	500	0.07
1000	0.45	1000	0.19	1000	0.19	1000	0.20	1000	0.28
1500	0.95	1500	0.42	1500	0.42	1500	0.45	1500	0.62
2000	1.68	2000	0.77	2000	0.74	2000	0.79	2000	1.09
2500	2.66	2500	1.17	2500	1.16	2500	1.24	2500	1.71
3000	3.84	3000	1.67	3000	1.66	3000	1.78	3000	2.46
3500	5.22	3500	2.29	3500	2.26	3500	2.42	3500	3.35
4000	6.82	4000	2.96	4000	2.95	4000	3.16	4000	4.37



Ruskin Company certifies that model TED50GS shown herein is licensed to bear the AMCA seal. The AMCA Certified Ratings Seal applies to Air Leakage, Air Performance and Energy Efficiency ratings. The ratings shown are based on tests and procedures performed in accordance with AMCA publication 511 and comply with the requirements of the AMCA Certified Ratings Program

LEAKAGE DATA

Leakage testing is performed in accordance with ANSI/AMCA Standard 500-D, figure 5.

Air performance testing is performed in accordance with ANSI/AMCA Standard 500-D, figures 5.2, 5.3 and 5.

Data are based on a closing torque of 7 inch pounds /ft² (.79 N.m./m²) and operation between 32°-120°F (0°-49°C).

*Leakage Class Definitions

As defined by AMCA, the maximum allowable leakage is as follows:

Leakage Class 1A (is only defined @ 1" wg)

- ▶ 3 cfm/ft² (.92 cmm/m²) @ 1" wg (0.25 kPa)

Leakage Class 1

- ▶ 4 cfm/ft² (1.22 cmm/m²) @ 1" wg (0.25 kPa)
- ▶ 8 cfm/ft² (2.44 cmm/m²) @ 4" wg (1 kPa)
- ▶ 11 cfm/ft² (3.45 cmm/m²) @ 8" wg (2 kPa)

TED50GS	LEAKAGE CLASS*			
Maximum Damper Width	1" w.g. (0.25 kPa)	4" w.g. (1 kPa)	8" w.g. (2 kPa)	10" w.g. (2.5 kPa)
48" (1219)	1A	1	1	1

DIMENSIONAL INFORMATION

Frame styles dimensioned to O.D. of frame

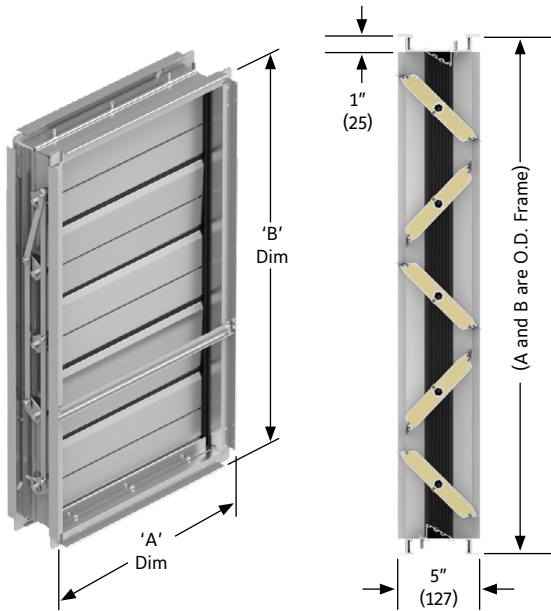

CHANNEL FRAME

Frame styles dimensioned to O.D. of frame

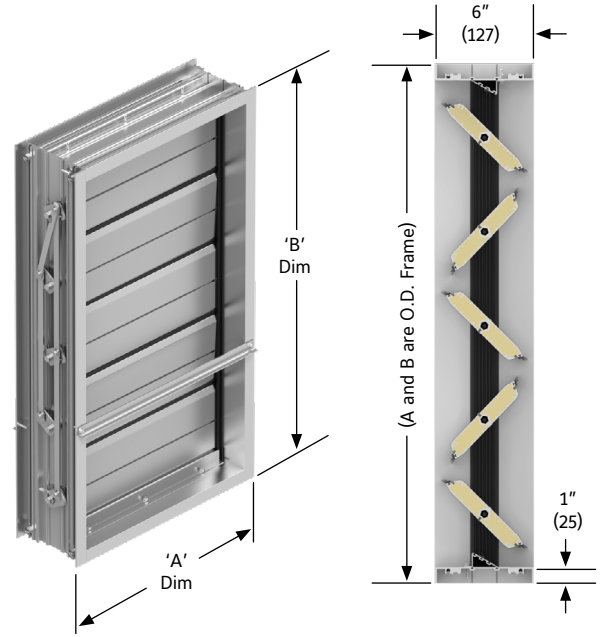

THERMAL BROKE FRAME

INSULATED AIRFOIL BLADE DETAILS

No thermal path from conditioned side to nonconditioned side of damper



BLADE SEAL DETAIL

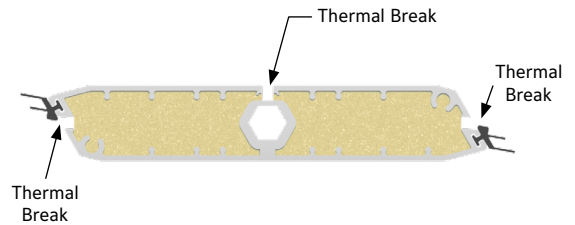

BLADE DETAIL

CONSTRUCTION INFORMATION

Channel Frame and Flange Frame Options

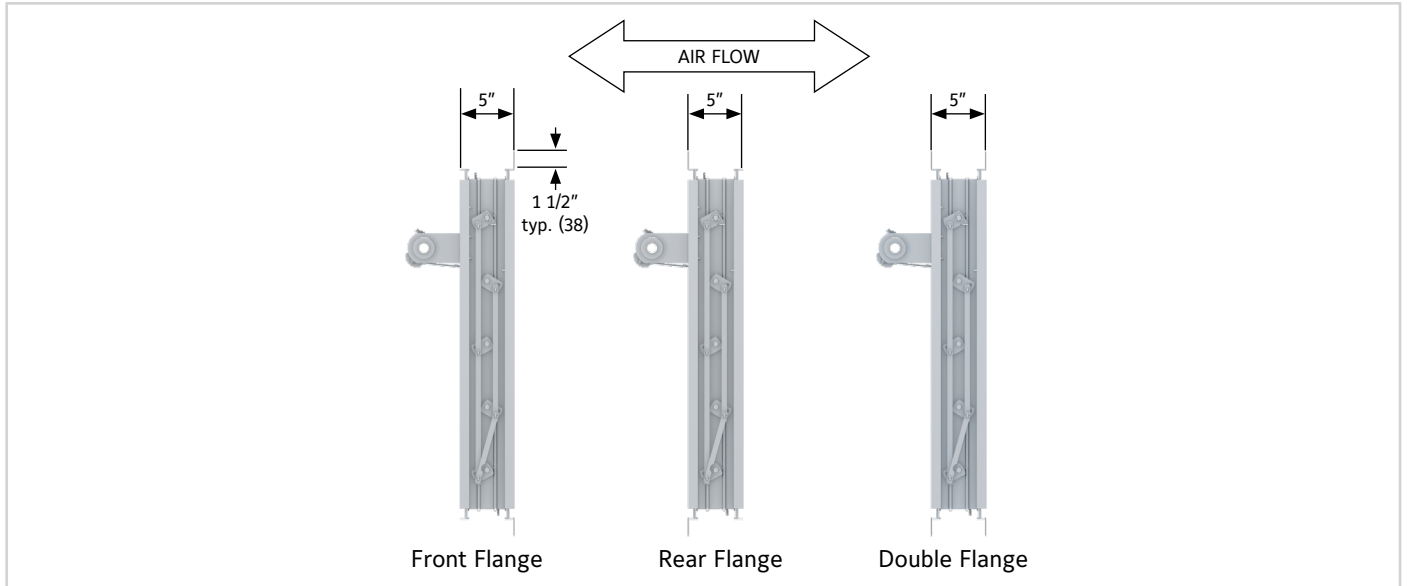

Ruskin TED50GS is rated for airflow in either direction, but Ruskin defines the “front” of the damper as the opposite side of the jackshaft and the “rear” as the jackshaft side. Unless specifically ordered otherwise, when looking at the concealed linkage side of the damper and the bottom blade turns clockwise to open, then the “front” surface is adjacent on the right.

CONSTRUCTION & DIMENSIONAL INFORMATION

Multi-section Dampers

Dampers over the maximum single section size will require multiple damper sections, typically built in equal sizes. Multi-section assemblies will have independent jackshaft operation.

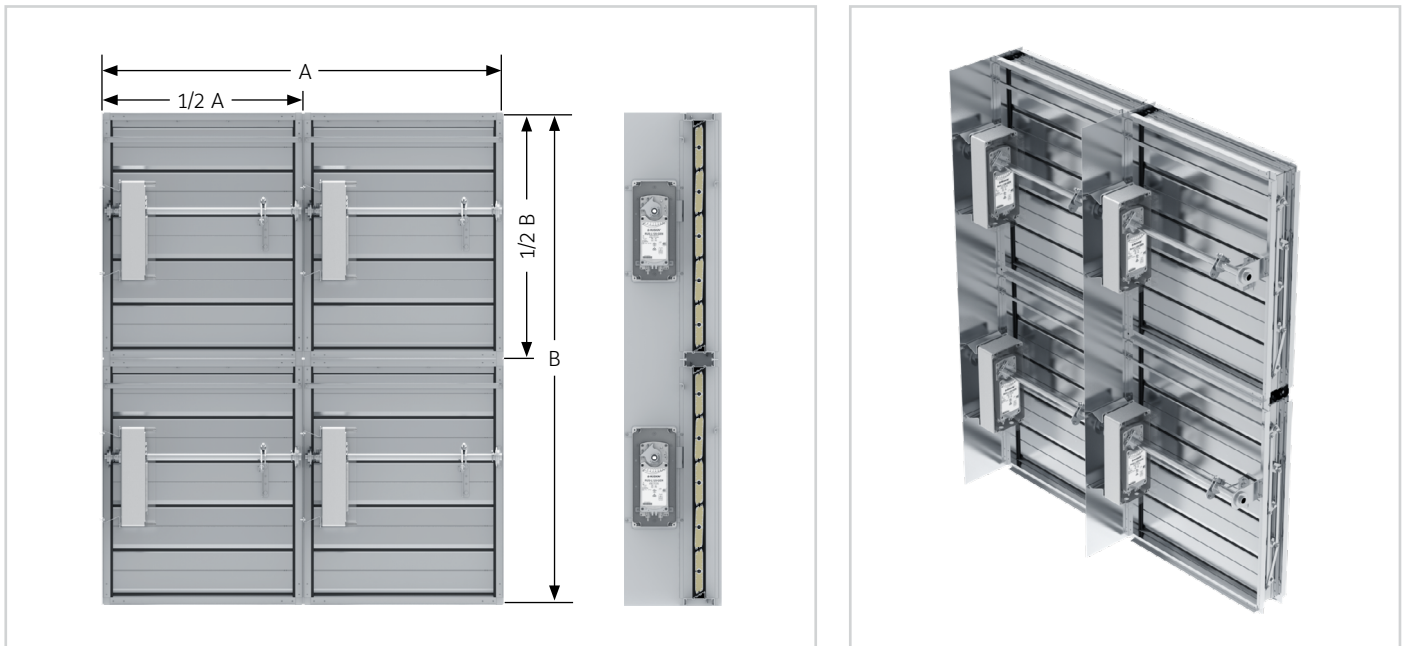

Note: Multiple section dampers are not intended to be structural supports. Additional bracing is recommended to support the damper weight and support against system pressure. Refer to Installation Instructions.

NOTE: 1. Refer to Installation Instructions for additional details.

TYPICAL ACTUATOR MOUNTING DETAILS

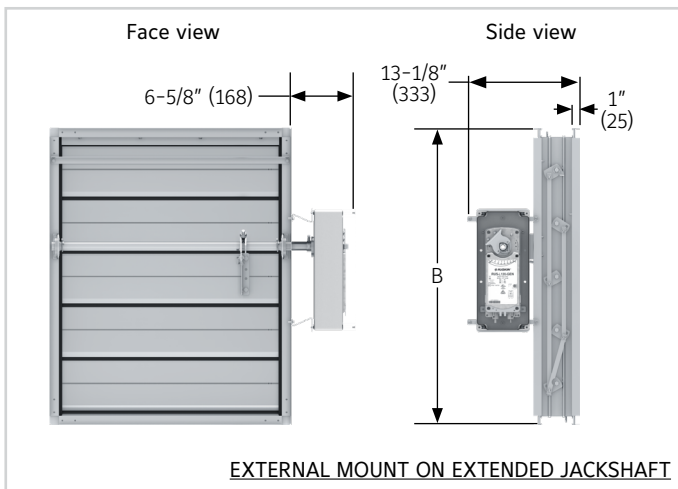
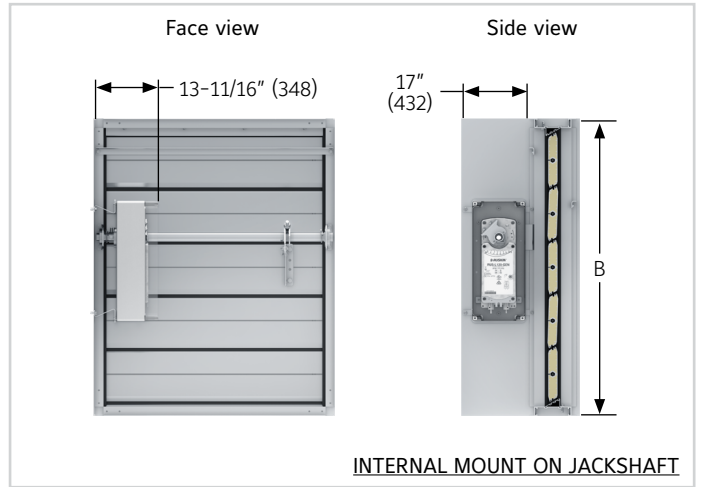
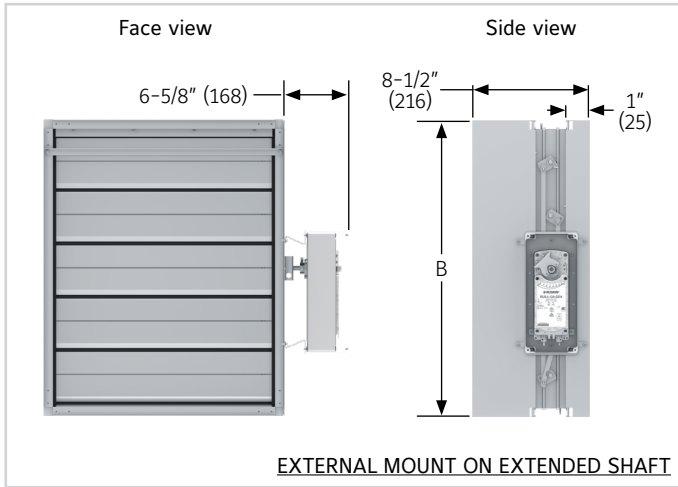

SUGGESTED SPECIFICATION

Furnish and install, where shown on plans and/or as indicated in schedules thermally efficient control dampers meeting the following minimum specifications.

Damper shall be Ruskin TED50GS. Damper frame shall be constructed of 6063T6 high yield extruded aluminum with a minimum wall thickness of .07" (2) and a yield stress of no less than 30,000psi. Low pressure drop aerodynamically shaped blades shall be constructed of 6063T6 high yield extruded aluminum with a minimum wall thickness of .07 (2) and a yield stress of no less than 30,000psi. Blades shall be filled with Polyurethane structural foam with a minimum density of 15 pcf. Insulated blades shall include a thermal break positioned between two blade seals to completely eliminate a thermal path from one side of the damper to the other. Thermal breaks on the blade edges shall not be visible when the damper is in the closed position. Damper assembly shall have a symmetrical design to ensure the resistance to airflow is identical from either direction. Axles shall be 1/2" (13) hexagonal plated steel material. Stainless steel axles shall be utilized when noted on the plans. Polycarbonate bearings shall be formed to the shape of the axle to reduce leakage through the frame. Bearings shall rotate inside an Acetal Copolymer outer bearing surface to reduce torque and promote a smooth operation throughout the stroke of the damper. Zero tolerance Swedgelock™ linkage arms shall be permanently and mechanically secured to each axle, eliminating future need for field adjustment of the linkage assembly. Linkage assembly shall be set to predetermined parameters ensuring leakage performance for the life of the product. Linkage shall be completely concealed within the damper frame, out of the airstream. Stainless steel linkage of the same design shall be used when specified on the plans. Blade edge seals shall be extruded Santoprene™ and shall be mechanically fastened to the blades. Jamb seals shall be low profile, light prohibiting, extruded Santoprene™ secured in extruded pockets of the damper frame. Stainless steel jamb seals creating a thermal path from one side of the blade to the other are not permitted. Damper shall be suitable for pressures up to 6 inches water gage (1.5kPa), velocities up to 4,000 fpm (20.3 m/s), standard air leakage of less than 8 cfm/ft² at 4 inches water gage (2.44 cmm/m² at 1 kPa), temperature range of -45°F to 185°F (-43°C to 85°C) and an R value no less than 2.16. All performance data shall be submitted to engineer of record for approval. Damper leakage, performance shall be in accordance with the latest edition of AMCA 500-D, and shall be tested and licensed in accordance with AMCA 511 for Air Performance and Air Leakage. Damper widths from 12" to 48" (305 to 1219) wide shall not leak any greater than 3 cfm/sq.ft. at 1" w.g. (15.2 l/s-m² at .25 kPa). Damper shall be factory equipped with fast acting 8-second spring return electric actuator with 40,000 open/closed cycle testing and shall be equivalent in all respects to Ruskin Model TED50GS.

LINKS TO IMPORTANT DOCUMENTS

Document Title
O & M for Commercial Control Dampers
SP100 and SP100FK Switch Package
Replacement Parts Catalog
Flange Frame Options
Limited Warranty Document

3900 Doctor Greaves Road
Grandview, MO 64030
Website: www.ruskin.com
Phone: (816) 761-7476