

# STAND ALONE ERV S-SERIES

## INSTALLATION INSTRUCTIONS

SXX-2ERV  
OCTOBER 6, 2015  
SUPERCEDES 08-16-13

ENERGY RECOVERY VENTILATOR

SERIES S11, S20, S28, S36, S46 & S62

### INSTALLATION INSTRUCTIONS FOR ENERGY RECOVERY VENTILATOR (FIXED) FOR STAND ALONE ROOFTOP APPLICATION



Energy recovery COMPONENT certified to the AHRI Air-to-Air Energy Recovery Ventilation Equipment Certification Program in accordance with AHRI Standard 1060-2000. Actual performance in packaged equipment may vary.



Intertek

ETL Certified per UL 1995 and CSA 22.2

#### I - Shipping and Packing List

Package contains:

- 1 — Energy Recovery Ventilator Assembly
- 2 — Assembled Exhaust Hood

#### II - Shipping Damage

Check the unit for shipping damage. Receiving party should contact last carrier immediately if shipping damage is found.

#### III - General

These instructions are intended as a general guide and do not supersede local codes in any way. Authorities having jurisdiction should be consulted before installation.

#### IV - Requirements

When installed, the unit must be electrically wired and grounded in accordance with local codes or, in absence of local codes, with the current National Electric Code, ANSI/NFPA No. 70.

#### V - Application

These Energy Recovery Ventilators (ERVs) are used in a side discharge manner equipped with a field provided balancing damper assembly through ductwork on the roof. A roof curb must be provided by contractor to manufacturers specifications. These ventilators conserve energy by transferring humidity and heat energy across two opposing air streams using a rotary heat exchanger (the energy recovery wheel). This process works in the summer by rejecting heat energy from incoming intake air and in the winter by conserving heat energy from the exhaust air, allowing outdoor ventilation rates to be increased by factors of three or more without additional energy penalty or increase in size of heating or air conditioning systems.

#### VI - Rigging for lifting

1. Maximum weight of the unit varies per series (300-1200 lbs crated)
2. Remove crating
3. All panels must be in place for rigging.
4. Remove box containing screws and accessories from the Controls section.
5. Roof curb should be secured before installing ERV on curb. (refer to roof curb install instructions).

6. Forklift channels (if used) must be removed from the base of the ERV before setting unit on curb. See Figure 1.
7. Attach lifting straps to the provided lifting lugs on the top 4 corners of the unit.
8. Position unit on roof curb being sure to provide service access to ERV control access door and wheel.

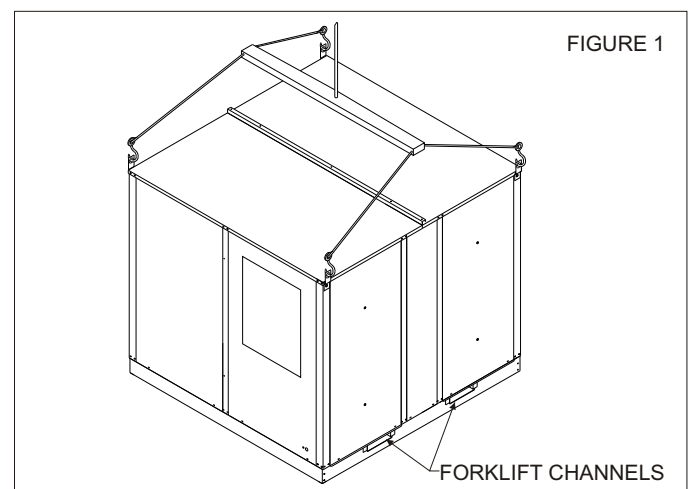

## VII - Installation

1. Install exhaust hood assembly shipped with ERV on pallet using screws provided in accessory box. On units with motorized exhaust damper connect Plug (P.161) to jack after removing PK-3 jumper before attaching hood with screws. **See Figure 2.**

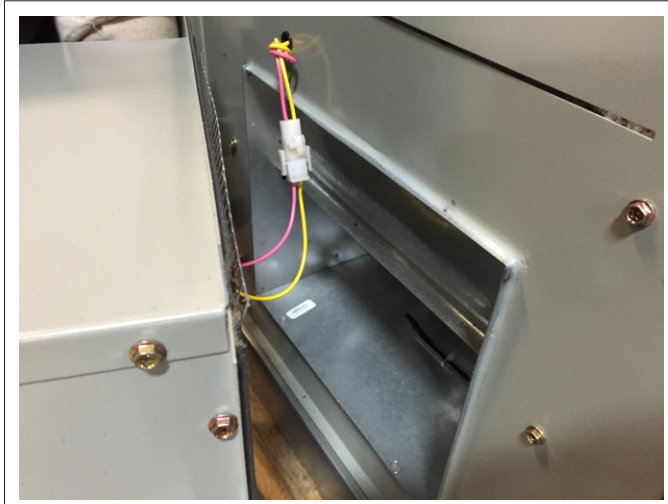

FIGURE 2

2. Remove ERV control access panels to connect field wiring.

### Low Voltage

3. Route Class II low voltage wire (3 conductor) from thermostat, relay, or Energy Management through small bushing provided in the end panel in the ERV. **See Figure 3** for location of penetration.

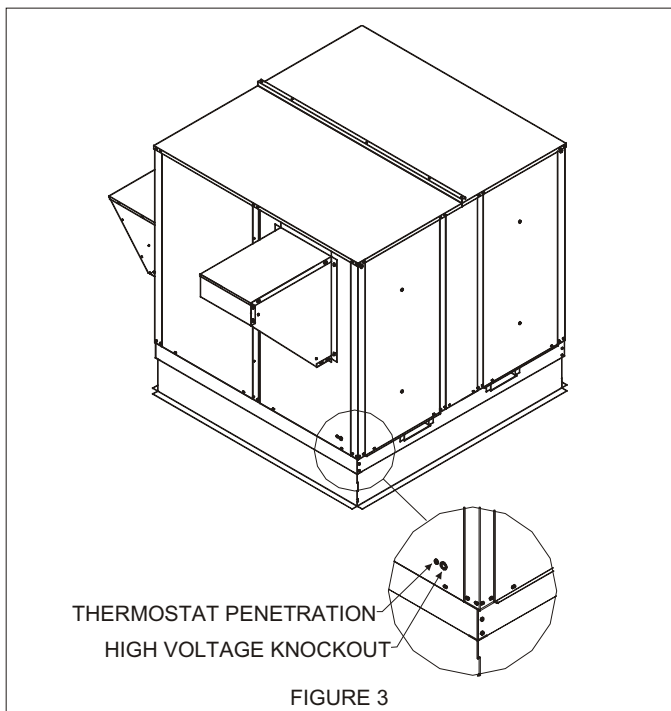

FIGURE 3

4. Connect low voltage wires to terminals 1-3 on the control board according to the Mechanical Engineers chosen controls scheme. **See Stand Alone ERV Controls Schemes for options on Page 3.**
5. On units with Variable Frequency Drives a separate terminal strip is provided to connect low voltage (0-10 VDC) controls [field supplied] for the Drives.

### High Voltage

6. All Electrical connections must conform to any local codes and current National Electric Codes (NEC) or Canadian Electric Codes (CEC). Refer closely to unit wiring diagram in the unit and/or in these instructions for proper wiring connections.
7. Refer to unit nameplate for minimum circuit ampacity (MCA) and maximum overcurrent protection size (fuse).
8. Electrical data is listed on unit rating plate as well as the motor name plates.
9. Connect line voltage power from field installed power disconnect to ERV fuse block in the control box of the unit. Use provided knockout on outside panel next to controls section. **See Wiring Diagram pg???**
10. **Ground unit with suitable ground connection** either through unit supply wiring or to an earth ground.

**Note: Unit voltage entries must be sealed weather tight after wiring is complete.**

11. Remove motor access panels, check that blowers have belts in place and that motors spin freely. Blower RPM can be adjusted to meet CFM and external static pressure requirements by adjusting the sheave on the blower motors and by replacing the pulley kits on units ordered without variable frequency drives. Multiple pulley arrangements are available from the manufacturer to meet the entire range of the units CFM options.

**Caution: Blower speed must be adjusted for the given external static pressure and airflow (CFM) requirements. If blower speed is not adjusted for conditions, possible motor overloading can occur.**

12. Unit Startup. Turn on power disconnect, turn on unit either from controls or by Jumping 24v+ from transformer (blue low voltage wire) to terminal #1. Check that motors are spinning the right direction (3 phase units only) that the enthalpy wheel is spinning and that motorized intake air and exhaust dampers are opening.

**If unit is operating properly proceed to next step, if not operating properly See Trouble shooting guide on Page 4.**

13. Clean up, caulk any open joints, holes or seams to make the unit completely air and water tight. Remove any jumpers, replace all access panels on the unit and secure.
14. Leave this instruction manual with the owner or in an envelope near the unit.

**See System Check or Trouble shooting guide for further information on the proper operation of the ERV.**

## VIII - Stand Alone ERV Controls Schemes

### Dependent options

**Thermostat:** This is the standard way to wire an ERV, when the ductwork of the stand alone ERV is attached to the ductwork of a single AC system the controls of the ERV should be wired in parallel with the controls with "G" to 1, "C" to 2 and "W" to 3. The ERV will operate when ever the RTU's blower is operating.

**Energy Management – Building Management Systems:** The ERV needs a 24 Volt AC signal to operate, connect the 24V+ to 1 and the 24V C to 2, the unit can be operated off of a relay or BMS controller if necessary.

### Dedicated options

When using a control method that does not involve an outside 24V controls signal power can be borrowed from the unit's transformer for short thermostat wire runs. Any run over 150' however should be powered by a separate transformer.

**Thermostat:** When using an ERV to service a large area with multiple AC units or when not tying directly into the ductwork of a single AC system the ERV can be run off of its own Thermostat. Splice the 24V+ wire "R" onto the XFORMER + terminal of the ERV control board, then wire "G" and "C" onto terminals 1 and 2 respectively, program Thermostat to energize G when space is occupied.

**CO<sub>2</sub> Sensor/ Transmitter:** An ERV can be wired to a wall mounted CO<sub>2</sub> Sensor/ Transmitter with relay like Johnson Controls CD-WR0-00-0 (or CD-WRD-00-0) in order to operate the ERV when ventilation is required due to high CO<sub>2</sub> levels. This type of transmitter has an adjustable set point, and a relay that the 24V+ signal can be wired into and "G" wire can be wired out of. "G" should be wired to #1 terminal. The ERV will then turn on and provide fresh air to the space to lower CO<sub>2</sub> levels.

**Quickstep:** Units equipped with the Quick Step controls option use an onboard microprocessor, factory installed CO<sub>2</sub> sensor and variable frequency drives to modulate airflow through the ERV to control for Carbon Dioxide. To operate the unit enter the Supply and Exhaust CFM values (they do not have to be the same value) into the Quick Step flexstat control along with maximum CO<sub>2</sub> level and the controls will modulate the blowers to ensure CO<sub>2</sub> levels are not above set point.

**ON/OFF switch or Timer:** Wire 24V+ from transformer onto the input of the switch and connect the output of the switch to terminal 1 on the control board. The ERV can be turned on manually or be set to turn on at a regular schedule when the building is occupied.

## IX – Operation

### How It Works.

The unit contains an energy recovery wheel (ERW) that is a revolutionary concept in rotary air-to-air heat exchangers. Designed as a packaged unit for ease of installation and maintenance, only the connection of electrical power is required to make the system operational.

When slowly rotating through counter flowing exhaust and fresh air streams the ERW absorbs sensible heat and latent heat from the warmer air stream in the first half of its rotation and transfers this total energy to the cooler air stream during the second half of this rotating cycle.

Rotating at 50-60 RPM, the ERW provides a constant flow of energy from the warmer to the cooler air stream. The large energy transfer surface and laminar flow through the ERW causes this constant flow of recovered energy to represent up to 85% of the difference in total energy contained within the two air streams.

Sensible and latent heat are the two components of total heat, sensible heat is energy contained in dry air and latent heat is the energy contained within the moisture of the air. The latent heat load from the outdoor fresh air on an air conditioning system can often be two to three times that of the sensible heat load and in the winter it is a significant part of a humidification heat load.

During both the summer and the winter, the ERW transfers moisture entirely in the vapor phase. This eliminates wet surfaces that retain dust and promote fungal growth as well as the need for a condensate pan and drain to carry water.

Because it is constantly rotating when in the air stream, the ERW is always being cleaned by air, first in one direction and then the other. Because it is always dry, dust or other particles impinging on the surface during one half of the cycle are readily removed during the next half of the cycle.

During the heating season, when outdoor air temperatures are below 15°F, it is recommended to use the (optional) low ambient kit.

### Optional Kits

#### *Motorized Intake Air Damper*

This damper mounts inside the outdoor air intake hood, it opens when the ERV supply blower is energized and closes when de-energized.

#### *Motorized Exhaust Air Damper*

Damper mounts inside the exhaust air hood, it opens when the ERV is energize and closes when the ERV is de-energized.

#### *Pressure Sensors*

Measurement devices (Magnahelics) on ERV that measure pressure across the energy recovery wheel.

#### *Rotation Sensor*

A magnetic sensor and logic board that measure pulses from a magnet on the spinning energy recovery wheel. A lack of measured pulses after initial start up results in an alarm. The alarm can be wired into building management hardware or to a thermostat with alarm switch terminals, it will warn that the wheel has stopped spinning, but does not otherwise effect operation.

#### *Stop, Start, Jog [Climate Smart]*

This option adds an Economizer or free cooling mode to the ERV. The wheel stops spinning to allow air to pass without energy transfer, starting and spinning intermittently in order to keep the wheel clean.

#### *Low Ambient Kit*

Prevents frost buildup on energy recovery wheel by terminating intake air when the discharge air temperature falls below a set level. Intake blower operation resumes after a 16°F rise above the field adjustable set point.

The frost threshold is the outdoor temperature at which frost will begin to form on the ERV wheel. For energy recovery ventilators, the frost is typically below 10°F. Frost threshold is dependent on indoor temperature and humidity. The table shows how the frost threshold temperatures vary depending on indoor conditions.

FROST THRESHOLD TEMPERATURE	
INDOOR RH AT 70°F	FROST THRESHOLD TEMPERATURE
20%	0°F
30%	5°F
40%	10°F

Because energy recovery ventilators have a low frost threshold, frost control options are not necessary in many climates. The Low Ambient Kit is available for units installed where outdoor temperatures may drop below the frost threshold during the ERV operational hours.

#### *Filter Racks/ Filter Options*

Stand alone units come with return air filters standard, MERV 8, 11, or 13 filters can be ordered with the unit. Supply air filter racks can be added as an option with the same efficiency filter options.

#### *Dirty Filter Switches*

Pressure differential switches that can be hooked up to an alarm to alert when pressure drops across a filter bank indicating dirty or clogged filter, they do not otherwise effect operation.

#### *Wheel Type*

While the standard energy recovery wheel absorbs both sensible and latent heat a sensible only wheel can be ordered for applications where the sensible portion of the heat load needs to be removed from a space without returning the humidity.

#### *Smoke Detector*

Smoke detectors can be factory ordered with the ERV, a qualified technician needs to field wire the smoke detector into the controls to break common in case of alarm.

#### *CO<sub>2</sub> Sensor*

See Quickstep in Controls schemes. A factory installed CO<sub>2</sub> sensor can be added to the unit to adjust ventilation on a CO<sub>2</sub> parts per million demand. This sensor is mounted next to the return air inlet and is not a relay, it only provides feedback to the quick step controls to adjust motor speed and is not suitable to turn the unit on and off on CO<sub>2</sub> demand.

### **X – System Check**

1. Disconnect main power
2. On units controlled by thermostats turn T-stat fan switch to "On". Otherwise jump 24v+ to terminal #1.
3. Restore power to unit, observe ERV wheel rotation and both fresh air and exhaust air blowers.

**Note: If the low ambient kit is used the jumper between terminals 5&6 should be removed and replaced with blue and yellow wires for the sensor. If system check out is being done at low ambient temperatures this kit can cause the unit not to operate. Under these conditions jump terminals 5&6.**

4. Verify the ERV three phase blower motors are phased sequentially ensuring correct rotation and operation. If both blowers are running backwards:
  - A. Disconnect Power.
  - B. Reverse and two high voltage line in wires on the ERVs fuse block.
  - C. Reapply Power.

**Note: Blower Motor rotation is checked in factory, do not switch wires at contactors or on motors if blowers are spinning backwards at startup.**

5. Verify that both blower motors are operating under their full load AMP rating (FLA). The FLA can be found on each motor and on the unit's name plate.
6. Verify that the fresh air and exhaust air motorized dampers are opening and closing when unit turns on/off.

**Note: If unit is not operating properly refer to troubleshooting guide.**

7. Return damper settings. When tied into an HVAC system manually adjust the position of the field installed dampers to balance Air flow.
8. Static test ports are provided to verify intake and exhaust CFM, these ports can also be used with a temperature probe to verify temperature transfer through the wheel.

Adjustment to the blower speed is accomplished by changing the sheave setting on both fresh air and exhaust air blowers.

### **Flow / Blower Speed Adjustment**

Blower speed selection is accomplished by changing the sheave setting on both fresh air and exhaust air blowers. To set ERV for the required air flow (CFM), the external static pressure applied to the ERV (duct static) must be known. See the CFM vs External Static Pressure chart for the appropriate unit to determine the correct blower RPM for the specified CFM and External Static Pressure.

After blower speed adjustments have been made. Ensure that when the belt is replaced it is tensioned correctly. The motor mounting plate can be adjusted to tension the belt. If using a belt tension checker, adjust the span to the appropriate setting and check the belt deflection force. The belt deflection force should be between 5-8 lbs or the lowest tension at which the belt will not slip under peak load conditions.

1. Disconnect main power to unit before making adjustment to economizer and/or ERV unit.
2. Replace ERV control access cover.
3. Set thermostat to normal operating position.
4. Restore power to unit.

### **XI - Sequence of Operation**

1. The thermostat or Building Management System (BMS), sends a 24 Volt AC signal to the HVAC system for cooling, heating, fan only or ventilation operation.
2. The ERV is activated simultaneously with the blower of the AC system. The intake air blower, the exhaust blower and the enthalpy wheel motor of the ERV are activated, these motors will remain energized as long as the blower in the AC system is energized and the outdoor conditions are adequate for energy recovery.
3. If the optional motorized intake air damper is present, the damper must open causing a proving switch to close in order to energize the intake air blower (10-20 seconds after the exhaust blower and enthalpy wheel have started).
4. If the optional low ambient kit is present, and the temperature leaving the exhaust side of the enthalpy wheel is lower than the field adjusted set point on the

temperature sensor, the optional motorized fresh air damper will close and the intake blower will de-energize. The exhaust blower and enthalpy wheel motor will continue to operate until the temperature sensor has a 16F rise, at this point the enthalpy wheel should be defrosted and the optional motorized damper will open and the fresh air blower will reactivate.

5. If the start, stop, jog [Climate Smart] option is present and outside conditions are adequate for free cooling the enthalpy wheel motor will stop for 10 minutes to allow for cool air to enter the building. It will then start or jog the wheel for 1 minute to keep dirt from building up on the wheel.

## XII - Trouble Shooting guide

### ERV will not operate:

1. Quick check items.
  - A. Verify that the door switch is closed, the switch must be in the closed position in order to power the control board.
  - B. Verify 24V power to the control board at terminals Xformer + & -. If voltage is low check high voltage into the unit (sec 2-A) and check that the T-1 wire from the high voltage into the step down transformer is on the correct terminal (208v-230v-460V) for the units voltage.
  - C. Verify 24V to the control board's terminal strip at T-1 (G) and T-2 (Com) in Fan or Cool or T-2 (Com) and T-3 (W) in Heat. **These terminals must be powered by an external power source to operate the ERV.**

A jumper from Xformer + to T-1 can be used to test operation of the ERV if an external 24V controls signal is not available.

1. Verify high voltage to ERV
  - A. Verify that the unit has the proper voltage in at terminals L1, L2 and/or L3 at the fused high voltage connection terminal block. Voltage specifications are on the units name plate.
  - B. Verify that the fuses are good, (check voltage across fuses with power on, voltage should be 0) replace any bad fuses.

### ERV Has Power, But Motors Are Spinning Backwards

1. Motors are checked for proper rotation at the factory, if the motors are spinning backwards after install reverse the phase by switching two wires on the high voltage IN terminals.
2. If the motor is spinning backwards after replacement switch the L1 & L2 wires connected inside the motors access panel. Do not rewire unit.

\*Many of motors used in production of the ERVs are multi voltage (230/460V) motors. When replacing motors or diagnosing a motor that won't start. Care should be taken to make sure the wires inside the motors access panel are connected securely and in the proper configuration.

### ERV Has Power, But the Enthalpy Wheel Does Not Spin (Start Stop Jog #1)

1. If the unit has the Start, Stop, Jog option installed the enthalpy wheel motor will turn off for 10 minute intervals when outside conditions are optimal for free

cooling, the fresh air and exhaust blowers will continue running. The Start, Stop, Jog control board has a white test button that when pressed will bypass the boards logic and turn the enthalpy wheel on. See Start, Stop, Jog in Options/Accessories troubleshooting for further information.

2. With the power off, check that the wheel belt is in place and tight.
3. Check for 24 volts between terminals Exhaust (K163) A&B, if the unit doesn't have Start, Stop, Jog the relay is connected directly to the Exhaust A and B terminals on the control board. If terminals 1&2 or 3&2 are energized with 24V, there is 24V in to Xformer + & -, and there is no voltage to Exhaust A&B the board is bad.
4. If there is 24 Volts at Exhaust A&B trace wires to the enthalpy wheel relay, check terminals A&B on the Relay for 24 Volts, check for high voltage power into and out of the relay. If the relay is energized/closed and no power is passing from terminals 7 to 4 or 9 to 6 the relay is bad.
5. You can jump the enthalpy wheel relay to test its operation by running a jumper from the 24v out on the transformer (blue wire) to the A terminal on the relay after removing the pink wire.
6. If the relay is closing and there is proper voltage between terminals 4&6 on the relay check the wheel's motor for proper voltage by using a multi-meter at Plug P-150 next to the enthalpy wheel motor.
  - A. If voltage is present and this is a single phase motor (most units) check the motor's capacitor.
  - B. If the capacitor is bad replace the capacitor, continue testing the motor
  - C. If proper voltage is present and the capacitor is good check the wires into the motor for continuity, if there is no continuity through the windings a wire connection is loose or the motor is bad, check wire connections between harness and windings, if connections are good the motor is bad, replace motor.

### ERV Has Power But the Exhaust Blower Does Not Operate

1. With power off. On units with belts, check that the blower's belt is tight and in place, if it is loose adjust the motor or sheave to tighten it, if it is broken replace it.
2. Check the contactor (K-163) to see if the issue is with high voltage or low voltage, if the contactor is closed check the motor. If it is open, push closed to check that the motor starts then check controls
3. Check for 24 Volts between Exhaust A&B terminals on the control board.
  - A. If the controls are calling for operation but there are not 24 Volts between Exhaust A&B the board is bad.
  - B. If the controls are calling for operation and there are 24 Volts between Exhaust A&B check the yellow wire for direct connection to the proper contactor (K-136), then check the pink wire for continuity through the field installed exhaust damper motor (if option was chosen) or the factory installed plug (PK-3) at the Jack (J-161) located in the exhaust blower section.

3. If contactor is closed check voltage to the motor by testing wires at Plug P-151, proper voltage is listed on the unit's information tag. If there is proper voltage to the motor and the motor is not spinning the motor is bad. With single phase units check the capacitor, if capacitor is bad replace it then continue checking the motor.

### **ERV Has Power But The Intake Air Blower Does Not Operate**

1. With power off. On units with belts, check that the blower's belt is tight and in place, if it is loose adjust the motor or sheave to tighten it, if it is broken replace it.
2. Check the contactor (K-164) to see if the issue is with high voltage or low voltage. If the contactor is closed check the motor. If it is open, push closed to check that the motor starts, then check controls.
3. If the contactor is open check for 24 Volts between Fresh A&B terminals on the control board.
  - A. If the controls are calling for operation and there is no voltage between Fresh A&B check terminals 5&6 to see if low ambient kit is installed (blue and yellow wires installed instead of a jumper), jumping terminals 5&6 will bypass the low ambient sensor and energize terminals Fresh A&B. See Low Ambient Kit in Options/Accessories troubleshooting for further information.
  - B. If the controls are calling for operation and there is no voltage between Fresh A&B and there is continuity between terminals 5&6 then the board is bad.
  - C. If the controls are calling for operation and terminals Fresh A&B are energized but the contactor is not energizing, check the yellow wire from terminal Fresh B to contactor (K-164), check the orange wire for continuity from terminal Fresh A through factory installed fresh air damper plug (P-160) to contactor. In models without a fresh air damper option there should be an orange jumper between pins 3&4 on the P-160 plug, when the fresh air damper option is chosen these wires connect to an end switch that is closed by a cam when the fresh air damper opens. See Sequence of Operations.

1. If contactor is closed check voltage to the motor by testing wires at plug P-148, proper voltage is listed on the unit's information tag. If there is proper voltage to the motor and the motor is not spinning the motor is bad. With single phase units check the capacitor, if capacitor is bad replace it then check the motor.

### **ERV Has Power But The Motorized Fresh Air Damper Does Not open**

1. Verify 24V in between terminals 1&2 or 3&2
2. Check voltage at junction J-56 on the ERV control board, there should be 24V between J-56 1&2 during normal operation, If the unit has a low ambient kit installed and temperatures are low the controls de-energize J-56 and Fresh K-164 terminals on the control board, jump Terminals 5&6 on the Terminal strip to bypass see Low Ambient Kit in Options/Accessories Troubleshooting for further information.
3. If there is voltage at the control board check for 24V at plug P-160 between pins 1&2

4. If there is voltage at P-160 make sure the damper linkage isn't binding and that the wires are attached to the actuator firmly. If the actuator still doesn't move when 24V is applied replace the actuator.

### **ERV Has Power But The Motorized Exhaust Air Damper Does Not Open**

1. Verify 24V In between terminals 1&2 or 3&2
2. Check voltage at Exhaust A&B on control board
3. If there is voltage at Exhaust A&B on the control board, trace wires to the exhaust blower compartment and plug P-161, Check for 24V between Pins 1&3.
4. If there is 24V at plug P-161 make sure the field connected P-161 plug for the damper is inserted firmly into J-161, that the damper linkage isn't binding and that the wires are connected firmly to the actuator. If the damper actuator still does not move the actuator is bad.

### **Options and Accessories Troubleshooting**

#### ***Start, Stop, Jog [Climate Smart]***

The Start, Stop, Jog kit is an optional control board with temperature and/or enthalpy sensor(s) that stops the enthalpy wheel from spinning (and transferring heat) when temperature conditions are conducive for free cooling. The board will spin the wheel intermittently in 10 min off 1 min on intervals to keep dust from building up on the surface.

All units shipped with the Start, Stop, Jog option installed have the temperature and enthalpy sensors installed, and the jumper (J9) set to T(emp). A qualified tech can adjust the setting to E(nthalpy) only or Temp and Enthalpy by adjusting the jumper (J9).

The factory set points to allow for free cooling during ventilation are 40F-70F, but they can be field adjusted to narrow the band by adjusting two potentiometers while measuring VDC between the Com & High or Com & Low terminals (0 VDC = 40 degrees, low set point, 5 VDC = 70 degrees, high set point).

#### ***Low Ambient Kit***

The low ambient kit is an optional temperature probe on a normally closed switch that closes the fresh air damper and turns off the fresh air blower when temperatures in the blower compartment suggest a frosted enthalpy wheel. The adjustable sensor is factory set for 20F. The sensor is mounted in the blower compartment with its probe near the blower's inlet, it is wired into the terminal strip 5&6 terminals.

It can be tested in hot weather by turning the dial up to a higher temperature and checking to see if the normally closed relay opens. In cold weather if the "R" terminal and "W" terminal in the sensor show an open circuit the bulb can be warmed above the set-point at which point the relay should close.

#### ***Dirty Filter Switch***

Dirty filter switches are an optional kit that put an adjustable pressure switch with the Low inlet on the blower side of the filter and the High inlet connected to the far side of the filter via tubing. A dirty filter moves less air lowering the pressure on the fan side Low inlet closing the normally open sensor switch and allowing an alarm. The sensor(s) are wired into their own terminal strip and can be field wired in series (normally closed), in parallel (normally open) or individually to an alarm device.

**Note: The Dirty Filter switch is not wired into the logic of the ERV, it will not stop the ERV if filters are dirty, it will only set off a field installed alarm or warning that the filters are dirty and need to be changed.**

**Pressure Gauge**

An optional Magnahelic pressure gauge can be ordered as an option to check pressure in In W.C., the Magnahelics are factory installed in the doors of the ERV to give pressure readings in the different quadrants of the unit. Occasional re-zeroing of the gauge is required.

**Rotation Sensor**

The rotation sensor is an optional missing pulse detector powered off of the exhaust and wheel 24v signal. A sensor is mounted in the exhaust compartment near the wheel and senses rotation via a magnet on the outside frame of the wheel. Its output is wired to a terminal strip and an alarm can be connected to alert when rotation of the wheel has stopped.

If an alarm is going off and the wheel is rotating properly check that the rotation sensor is mounted and adjusted to properly sense the sensor magnet in the wheel. Check wire connections to make sure they are secure.

If an alarm is tripped and the wheel is not rotating check the wheels belt, it's motor, and capacitor for proper operation.

**XIII - Maintenance**

1. All motors use prelubricated sealed bearings; no further lubrication is necessary.
2. Make visual inspection of motors, belts and wheel rotating bearings during routine maintenance.
3. Eight pie-shaped segments, are seated on stops between the segment retainer which pivots on the wheel rim and secured to the hub and rim of wheel. Annual inspection of the self cleaning wheel is recommended. With power disconnected, remove ERV access panels (rear) and unplug [J150 & P150] **(Refer to wiring diagram in this instruction manual)**. Remove segment and wash with water and/or mild detergent.
4. To install wheel segments follow steps A through E . **See Figure 4.** Reverse procedure for segment removal.

- A. Unlock two segment retainers (one on each side of the selected segment opening).
- B. With the embedded stiffener facing the motor side, insert the nose of the segment between the hub plates.
- C. Holding segment by the two outer corners, press the segment towards the center of the wheel and inwards against the spoke flanges. If hand pressure does not fully seat the segment, insert the flat tip of a screw driver between the wheel rim and outer corners of the segment and apply downward force while guiding the segment into place.
- D. Close and latch each segment retainer under segment retaining catch.
- E. Slowly rotate the wheel 180°. Install the second segment opposite the first for counterbalance. Rotate the two installed segments 90° to balance the wheel while the third segment is installed. Rotate the wheel 180° again to install the fourth segment opposite the third. Repeat this sequence with the remaining four segments.

**XIV - Pulley Kit Installation**

The units are shipped from the factory at the low static setting. Pulley kits are available for the medium and high static settings. To install a pulley kit.

1. Check content of pulley kit, if pulley kit contains:
  - A. An adjustable sheave and a fixed pitch pulley then remove belt and both motor and blower pulley.
  - B. An adjustable sheave then remove the motor pulley.
  - C. A fixed pitch pulley then remove the blower pulley.
2. Replace pulley(s) with the pulley(s) from pulley kit. Make sure each pulley is installed with a key. Tighten the set screw on the pulley(s) to 100 in.lb.
3. Install the belt that came with the pulley kit. Tension belt as explained in the blower speed adjustment section.
4. Check the speed of the blower. Adjust the motor sheave to increase or decrease the speed of the blower. See blower adjustment section.

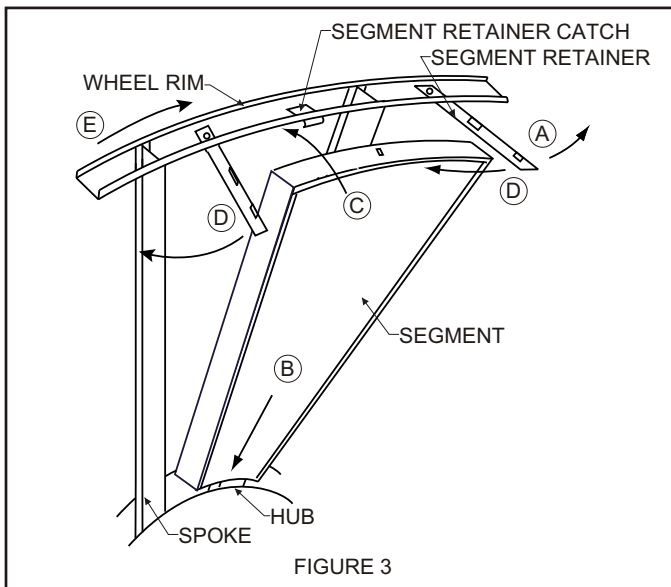

FIGURE 3

## S-02 Series Stand Alone ERV'S For Side by Side Duct Arrangements

### Features and Notes

1. Stand alone design allows higher levels of outdoor air to be introduced into the a/c space.
2. Static test ports provided to verify intake and exhaust CFM.
3. Balancing damper(s) is field provided when connected to ductwork. System will not operate properly without balancing damper.
4. Roof curbs are available for the ERV's.
5. See blower performance charts for airflow at various E.S.P..
6. Filter rack with 2" pleated filters included.

ERV Roof Curbs	
Series	Model No
S11	01-2D1-2514
S20	01-2D1-3014
S28	01-2D1-3614
S36	01-2D1-4114
S46	01-2D1-4614
S62	01-2D1-5214

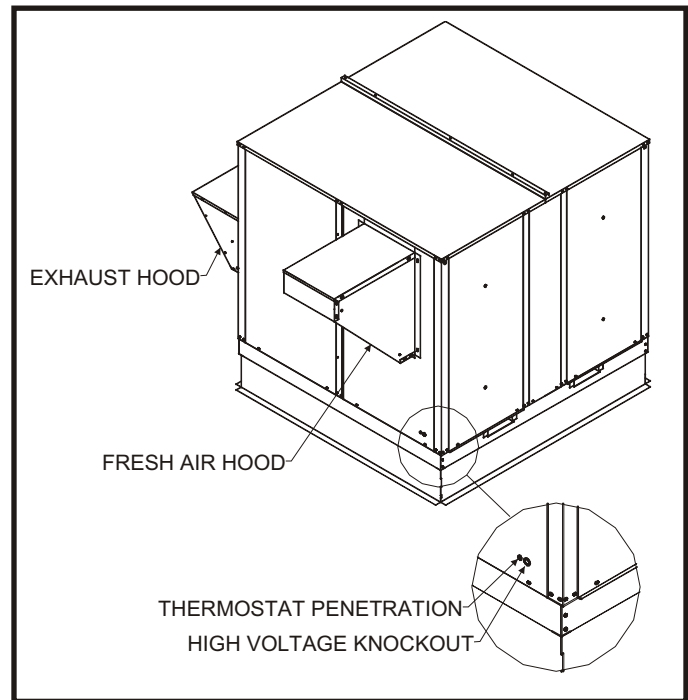
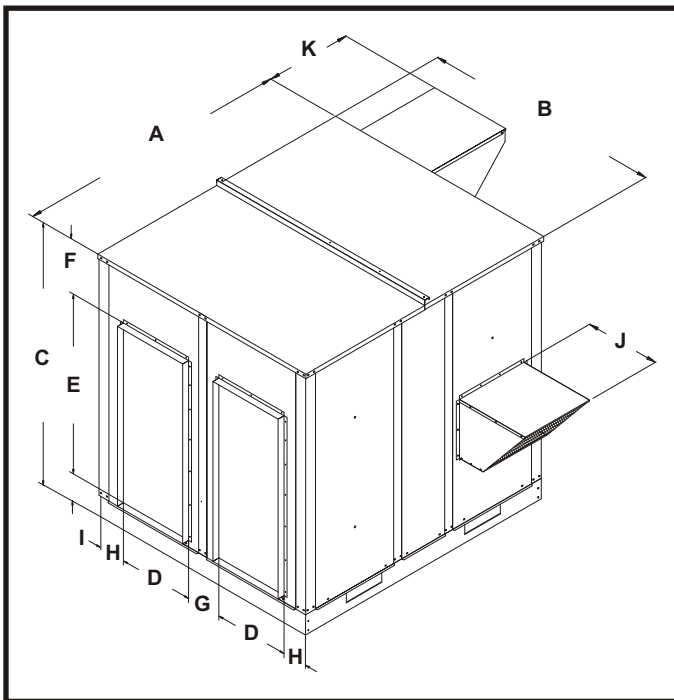

ERV Data		Dimensional Data										
ERV Series	CFM Range	A	B	C	D	E	F	G	H	I	J	K
S11-02	300-1100	44.75	32.13	33.50	11.00	27.00	4.00	4.25	2.88	2.50	20.75	14.38
S20-02	1200-2000	54.38	37.25	37.50	12.00	30.00	5.87	5.13	4.06	1.63	20.75	17.50
S28-02	1200-2800	52.25	42.63	43.56	14.00	32.00	8.69	5.25	4.25	2.88	20.75	25.50
S36-02	2000-3600	60.00	46.69	57.37	16.50	39.50	12.00	5.50	4.05	5.88	20.75	25.50
S46-02	3000-4600	60.00	52.69	57.37	16.50	39.50	12.00	8.69	5.50	5.88	20.75	28.06
S62-02	4600-6200	72.00	70.88	63.63	19.50	39.50	17.53	14.50	8.70	6.60	20.75	37.75







**COMPONENT CODE**

A131 Fixed Relay Board  
 B26 Motor, Exhaust Air  
 B27 Motor, Intake Air  
 B28 Motor, Desiccant Wheel  
 B30 Motor, Damper Intake (Optional)  
 B31 Motor, Damper Exhaust (Optional)  
 C23 Capacitor, Wheel Motor  
 F29 Fuse  
 J48 Jack, Control Box (Intake Air)  
 J50 Jack, Control Box (Wheel)  
 J51 Jack, Control Box (Exhaust Air)  
 J56 Jack, Control Box (Damper)  
 J148 Jack, Intake Air Motor Harness  
 J150 Jack, Wheel Motor Harness  
 J151 Jack, Exhaust Air Motor Harness

J152 Jack, Transformer (High Voltage)  
 J160 Jack, Damper Intake Motor Harness  
 J161 Jack, Damper Exhaust Motor Harness  
 K163 Contactor, Exhaust Air Motor  
 K164 Contactor, Intake Air Motor  
 MPD-1 Missing Pulse Detector Board (Optional)  
 P48 Plug, Intake Air Motor Harness  
 P50 Plug, Wheel Motor Harness  
 P51 Plug, Exhaust Air Motor Harness  
 P56 Plug, Damper Motor Harness  
 P148 Plug, Intake Air Motor  
 P150 Plug, Wheel Motor  
 P151 Plug, Exhaust Air Motor  
 P152 Plug, Transformer (High Voltage)  
 P160 Plug, Damper Intake Motor Harness

P161 Plug, Damper Exhaust Motor Harness  
 RS-1 Rotation Sensor (Optional)  
 S26 Switch, Low Ambient (Optional)  
 S51 Switch, Door  
 S52 Switch, Damper Intake  
 S53 Switch, Damper Exhaust  
 SD Smoke Detector (Optional)  
 SSJ Climate Smart Board (Optional)  
 T27 Transformer, Control  
 T28 Transformer, Step-down (Optional)  
 TB37 Terminal Block (Low Voltage)  
 TB39 Terminal Block (Monitoring)  
 WHL Relay, Wheel Motor

**WIRE COLOR CODE**

BK Black  
 BL Blue  
 GR Green  
 GY Gray  
 OR Orange  
 PK Pink  
 RD Red  
 WT White  
 YL Yellow

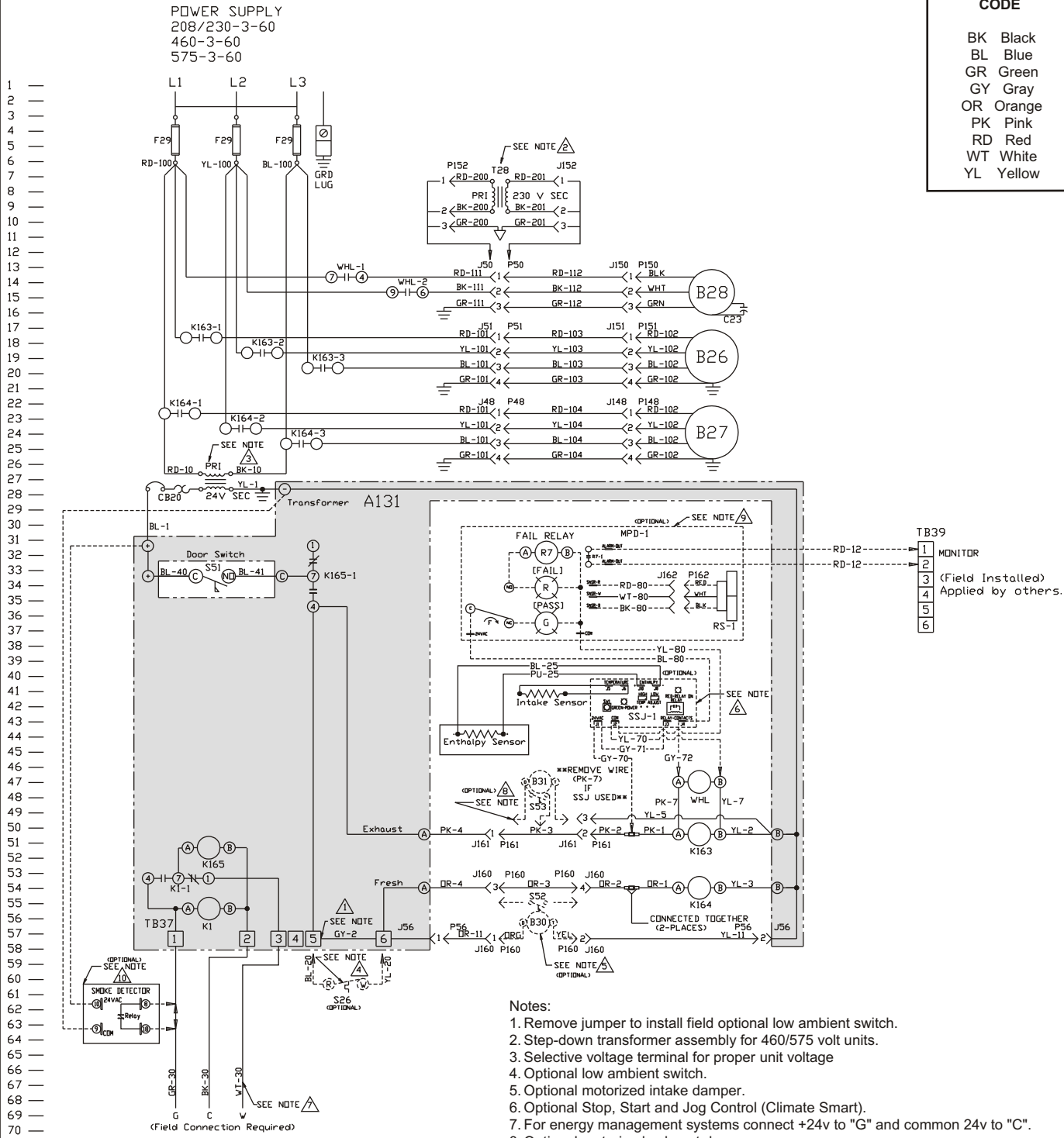

- Notes:
1. Remove jumper to install field optional low ambient switch.
  2. Step-down transformer assembly for 460/575 volt units.
  3. Selective voltage terminal for proper unit voltage
  4. Optional low ambient switch.
  5. Optional motorized intake damper.
  6. Optional Stop, Start and Jog Control (Climate Smart).
  7. For energy management systems connect +24v to "G" and common 24v to "C".
  8. Optional motorized exhaust damper.
  9. Optional wheel rotation sensor.

D11-D62-2ERV

# ERV UNIT WIRING DIAGRAM

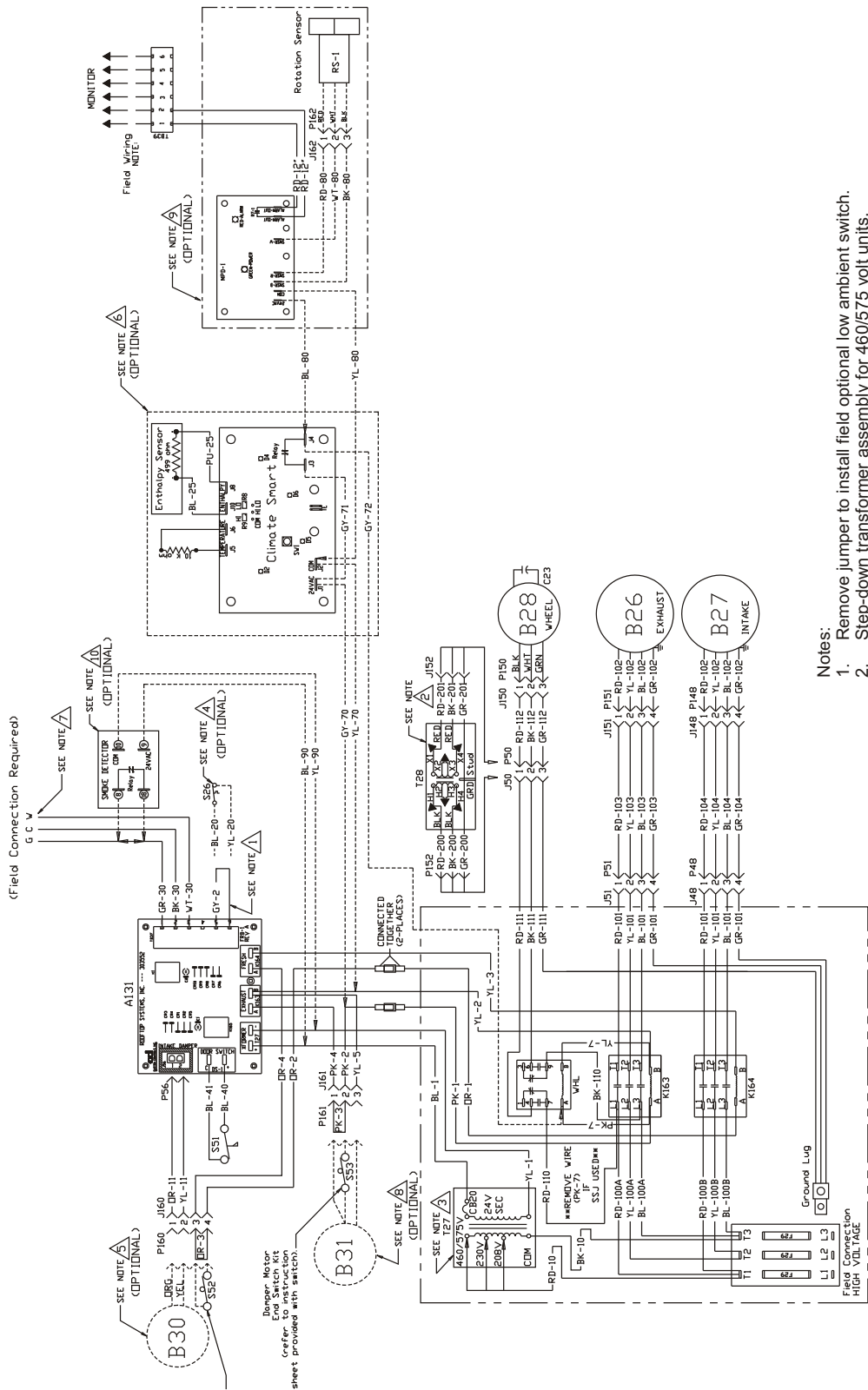

Desiccant Wheel for Rooftop Unit  
208-230/460/575V (3 PH)

Unit#: 01-D11-D62-02XX-23 thru -43

# ERV UNIT SCHEMATIC DIAGRAM

POWER SUPPLY  
208/230-3-60  
460-3-60  
575-3-60

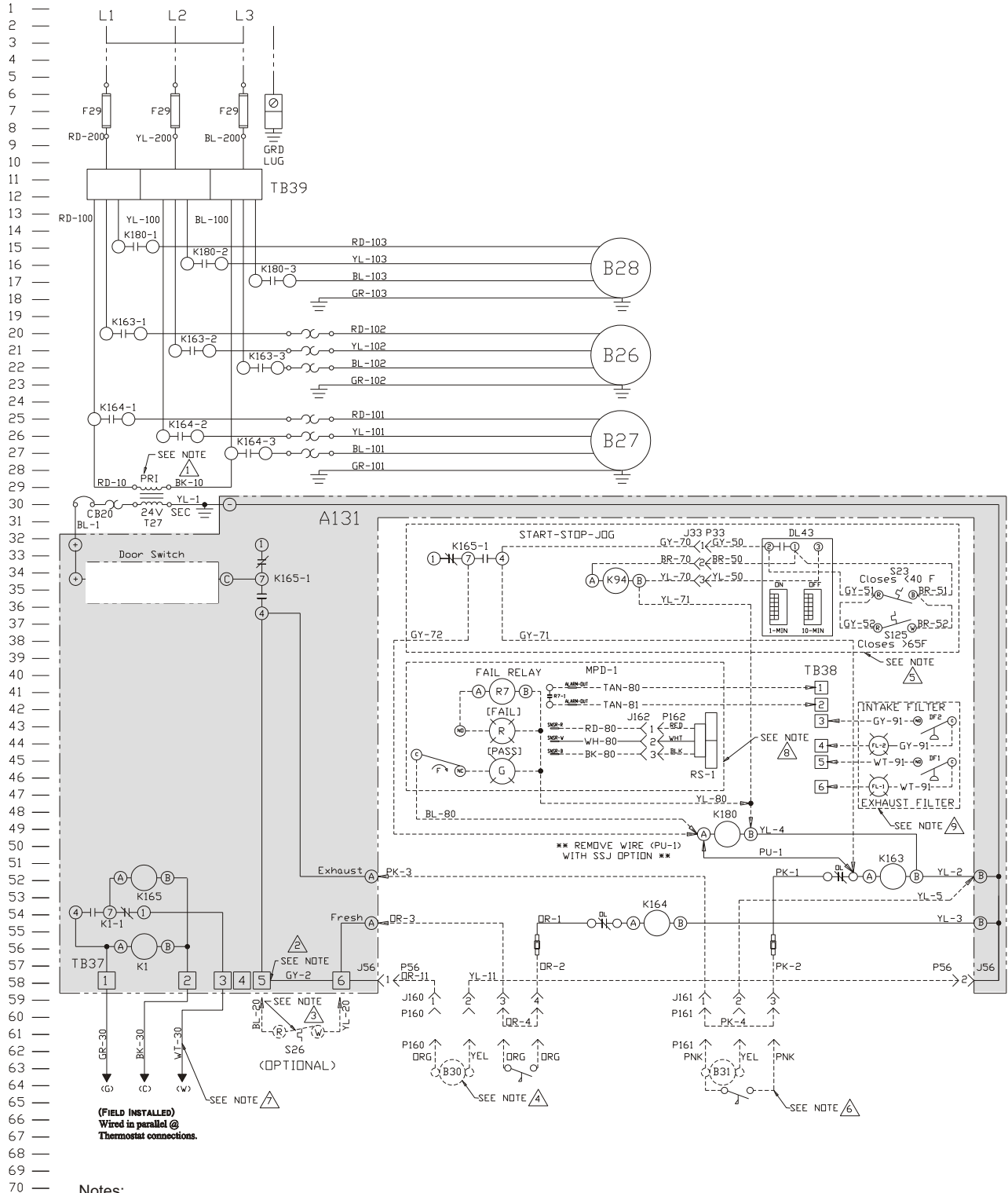

(FIELD INSTALLED)  
Wired in parallel @  
Thermostat connections.

**Notes:**

1. Selective voltage terminals for proper unit voltage.
2. Remove jumper to install field optional low ambient switch.
3. Optional low ambient switch.
4. Optional motorized intake damper.
5. Optional Stop, Start and Jog Control.
6. Optional Motorized Exhaust Damper
7. For energy management systems connect +24v to "G" and common 24v to "C".
8. Optional Wheel Rotation Detection.
9. Optional Dirty Filter Sensors.

# ERV UNIT WIRING DIAGRAM

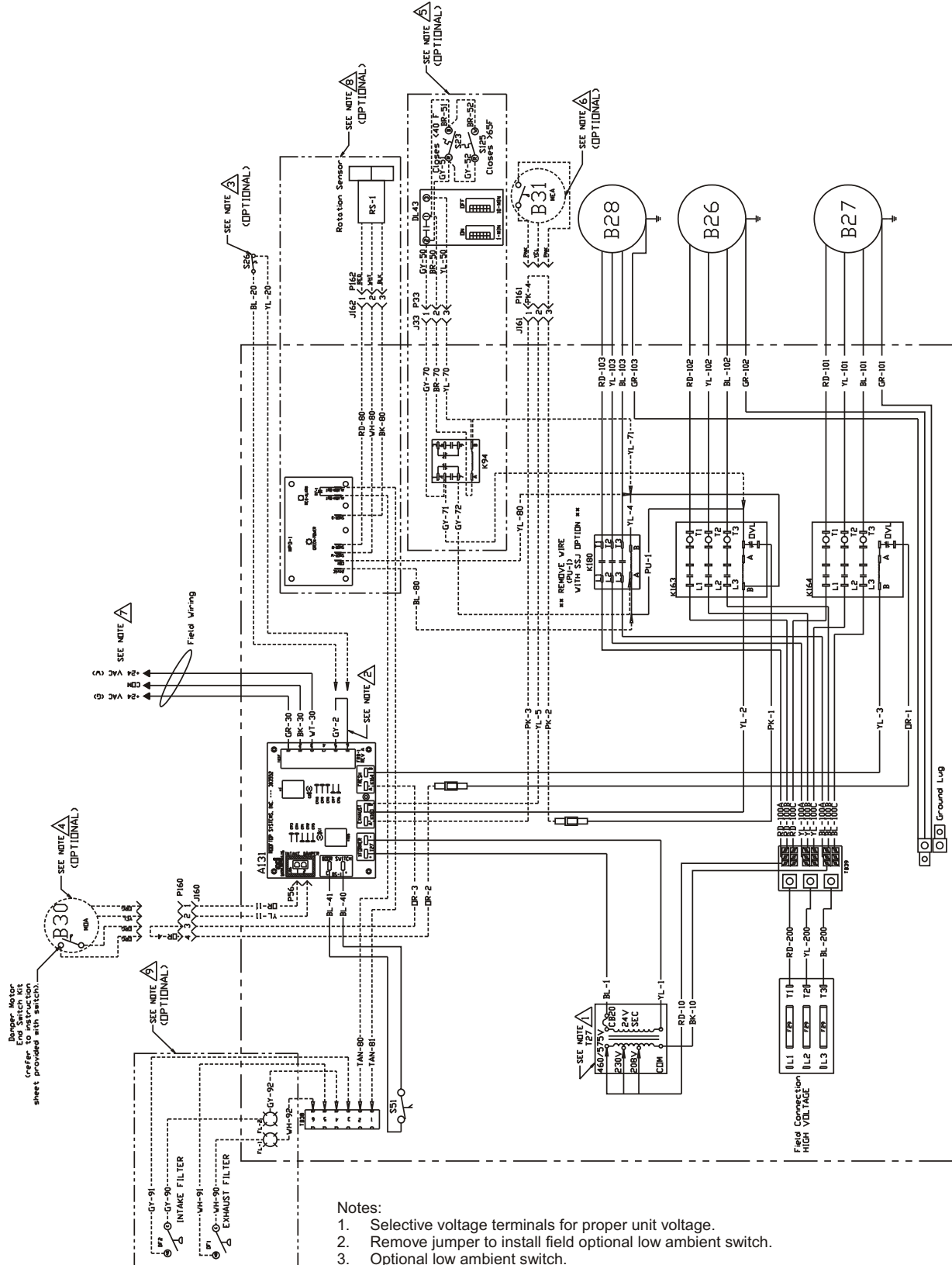

## Blower RPM for S11

### SUPPLY



		Mist Eliminator Filter in Intake Hood (1.5HP)						
		External Static Pressure (in water)						
		0	0.25	0.5	0.75	1	1.25	1.5
CFM	300	N/A	N/A	1020	1205	1365	1480	1590
	500	N/A	1015	1200	1320	1460	1565	1670
	700	990	1190	1315	1455	1560	1665	1715
	900	1150	1310	1450	1555	1660	1680	1795
	1100	1305	1440	1550	1655	1740	1815	1895

### EXHAUST

		Barometric Hood, 2" Pleated Filters (1.5HP)						
		External Static Pressure (in water)						
		0	0.25	0.5	0.75	1	1.25	1.5
CFM	300	N/A	N/A	1150	1285	1415	1515	1640
	500	N/A	1145	1275	1410	1510	1545	1720
	700	1140	1270	1405	1505	1590	1715	1815
	900	1320	1435	1585	1665	1705	1810	1930
	1100	1495	1580	1660	1755	1880	N/A	N/A

Notes:

1. Drive losses included in the above tables.
2. Performance can vary depending on ambient conditions
3. Blower RPMs are for reference only

		RPM Range		
	Low	1000-1300	Standard Unit	
	Medium	1300-1700	Optional Kit	
	High	1750-2200	Optional Kit	

## Blower RPM for S20

### SUPPLY



		Mist Eliminator Filter in Intake Hood (2HP)						
		External Static Pressure (in water)						
		0	0.25	0.5	0.75	1	1.25	1.5
CFM	1200	1065	1285	1375	1415	1495	1580	1685
	1400	1140	1330	1410	1440	1555	1660	1760
	1600	1290	1400	1480	1545	1670	1745	1835
	1800	1395	1470	1540	1665	1735	1800	1880
	2000	1460	1530	1650	1725	1795	1870	1960

### EXHAUST

		Barometric Hood, 2" Pleated Filters (2HP)						
		External Static Pressure (in water)						
		0	0.25	0.5	0.75	1	1.25	1.5
CFM	1200	1175	1290	1430	1520	1680	1765	1850
	1400	1245	1425	1515	1675	1755	1830	1920
	1600	1400	1505	1670	1750	1825	1910	1980
	1800	1495	1660	1740	1820	1900	1975	2090
	2000	1645	1730	1815	1895	1965	2080	2170

Notes:

1. Drive losses included in the above tables.
2. Performance can vary depending on ambient conditions
3. Blower RPMs are for reference only

		RPM Range		
	Low	1000-1300	Standard Unit	
	Medium	1300-1750	Optional Kit	
	High	1750-2200	Optional Kit	

## Blower RPM for S28

### SUPPLY



		Mist Eliminator Filter in Intake Hood (3HP)						
		External Static Pressure (in water)						
		0	0.25	0.5	0.75	1	1.25	1.5
CFM	1200	N/A	955	1070	1210	1370	1465	1550
	1600	N/A	1065	1205	1305	1460	1540	1595
	2000	1060	1200	1290	1445	1530	1585	1680
	2400	1190	1335	1440	1490	1575	1670	1755
	2800	1300	1460	1550	1645	1705	1750	1800

### EXHAUST

		Barometric Hood, 2" Pleated Filters (3HP)						
		External Static Pressure (in water)						
		0	0.25	0.5	0.75	1	1.25	1.5
CFM	1200	N/A	N/A	1025	1170	1270	1355	1400
	1600	N/A	1020	1155	1240	1330	1390	1490
	2000	1015	1150	1235	1325	1380	1475	1590
	2400	1140	1285	1365	1420	1510	1595	1640
	2800	1280	1345	1455	1540	1575	1670	1745

Notes:

1. Drive losses included in the above tables.
2. Performance can vary depending on ambient conditions
3. Blower RPMs are for reference only

RPM Range		
	Low	950-1320
	Medium	1325-1565
	High	1570-1880

Standard Unit  
Optional Kit  
Optional Kit

## Blower RPM for S36

### SUPPLY



		Mist Eliminator Filter in Intake Hood (3HP)						
		External Static Pressure (in water)						
		0	0.25	0.5	0.75	1	1.25	1.5
CFM	2000	815	925	1020	1105	1155	1255	1325
	2400	920	1060	1130	1215	1250	1355	1385
	2800	1010	1140	1240	1285	1370	1425	1470
	3200	1125	1235	1340	1385	1455	1465	N/A
	3600	1225	1375	1440	1460	1500	N/A	N/A

### EXHAUST

		Barometric Hood, 2" Pleated Filters (3HP)						
		External Static Pressure (in water)						
		0	0.25	0.5	0.75	1	1.25	1.5
CFM	2000	755	890	970	1060	1125	1215	1280
	2400	985	1035	1085	1140	1240	1275	1325
	2800	1020	1115	1175	1230	1270	1335	1370
	3200	1105	1200	1225	1285	1300	1390	1430
	3600	1155	1265	1295	1335	1385	N/A	N/A

Notes:

1. Drive losses included in the above tables.
2. Performance can vary depending on ambient conditions
3. Blower RPMs are for reference only

RPM Range		
	Low	700-1025
	Medium	1030-1305
	High	1325-1575

Standard Unit  
Optional Kit  
Optional Kit



## Blower RPM for S46

### SUPPLY



		Mist Eliminator Filter in Intake Hood (5HP)						
		External Static Pressure (in water)						
		0	0.25	0.5	0.75	1	1.25	1.5
CFM	3000	965	1085	1150	1230	1295	1345	1420
	3400	1035	1145	1250	1290	1335	1415	1475
	3800	1120	1245	1285	1315	1440	1470	1535
	4200	1215	1305	1355	1430	1465	1530	1595
	4600	1300	1375	1450	1460	1540	1590	1650

### EXHAUST

		Barometric Hood, 2" Pleated Filters (5HP)						
		External Static Pressure (in water)						
		0	0.25	0.5	0.75	1	1.25	1.5
CFM	3000	1010	1105	1195	1255	1300	1375	1415
	3400	1100	1190	1250	1320	1370	1410	1480
	3800	1185	1245	1360	1410	1440	1475	1540
	4200	1240	1355	1425	1465	1530	1590	1630
	4600	1345	1410	1485	1520	1585	1650	1700

Notes:

1. Drive losses included in the above tables.
2. Performance can vary depending on ambient conditions
3. Blower RPMs are for reference only

	RPM Range		
	Low	780-1020	Standard Unit
	Medium	1000-1315	Optional Kit
	High	1315-1700	Optional Kit

## Blower RPM for S62

### SUPPLY



		Mist Eliminator Filter in Intake Hood (5HP)						
		External Static Pressure (in water)						
		0	0.25	0.5	0.75	1	1.25	1.5
CFM	4600	795	900	1030	1075	1160	1220	1255
	5000	855	920	1070	1130	1190	1250	1275
	5400	880	950	1095	1155	1245	1270	1290
	5800	915	1035	1115	1175	1255	1280	N/A
	6200	985	1080	1135	1225	1265	N/A	N/A

### EXHAUST

		Barometric Hood, 2" Pleated Filters (5HP)						
		External Static Pressure (in water)						
		0	0.25	0.5	0.75	1	1.25	1.5
CFM	4600	705	885	985	1045	1100	1155	1215
	5000	825	950	1025	1095	1150	1210	1245
	5400	875	980	1080	1140	1190	1240	1275
	5800	935	995	1130	1180	1230	N/A	N/A
	6200	985	1095	1165	N/A	N/A	N/A	N/A

Notes:

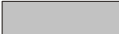
1. Drive losses included in the above tables.
2. Performance can vary depending on ambient conditions
3. Blower RPMs are for reference only

	RPM Range		
	Low	700-900	Standard Unit
	Medium	900-1100	Optional Kit
	High	1100-1300	Optional Kit





# START UP INFORMATION SHEET

## VOLTAGE - ERV UNIT

Incoming Voltage L1-L2 \_\_\_\_\_ L1-L3 \_\_\_\_\_ L2-L3 \_\_\_\_\_  
Running Voltage L1-L2 \_\_\_\_\_ L 1-L3 \_\_\_\_\_ L2-L3 \_\_\_\_\_  
Secondary Voltage \_\_\_\_\_ C (black) to G (green) Volts\* \_\_\_\_\_  
C (black) to W (white) Volts\* \_\_\_\_\_

\* With thermostat calling.

## AMPERAGE - ERV MOTORS

Intake Motor: Nominal HP \_\_\_\_\_ Rated Amps \_\_\_\_\_ Running Amps \_\_\_\_\_  
Exhaust Motor: Nominal HP \_\_\_\_\_ Rated Amps \_\_\_\_\_ Running Amps \_\_\_\_\_  
Wheel Motor: Nominal HP \_\_\_\_\_ Rated Amps \_\_\_\_\_ Running Amps \_\_\_\_\_

## AIRFLOW

Intake Design CFM \_\_\_\_\_ Pressure Drop \_\_\_\_\_ Calculated CFM \_\_\_\_\_  
Exhaust Design CFM \_\_\_\_\_ Pressure Drop \_\_\_\_\_ Calculated CFM \_\_\_\_\_  
Amb. db Temp \_\_\_\_\_ Return Air db Temp\* \_\_\_\_\_ Tempered Air db Temp\* \_\_\_\_\_  
Amb. wb Temp \_\_\_\_\_ Return Air wb Temp\* \_\_\_\_\_ Tempered Air wb Temp\* \_\_\_\_\_

\* Measure after 15 minutes of run time

---

## INSTALLATION CHECK LIST

Model # \_\_\_\_\_ Serial # \_\_\_\_\_  
Owner \_\_\_\_\_ Owner Phone # \_\_\_\_\_  
Owner Address \_\_\_\_\_  
Installing Contractor \_\_\_\_\_ Start Up Mechanic \_\_\_\_\_

- Inspect the unit for transit damage and report any damage on the carrier's freight bill.
- Check model number to insure it matches the job requirements.
- Install field accessories and unit adapter panels as required. Follow accessory and unit installation manuals.
- Verify field wiring, including the wiring to any accessories.
- Check all multi-tap transformers, to insure they are set to the proper incoming voltage.
- Verify correct belt tension, as well as the belt/pulley alignment. Tighten if needed.
- Prior to energizing the unit, inspect all the electrical connections.
- Power the unit. Bump the motor contactor to check rotation. Three phase motors are synchronized at the factory. If blower motor fans are running backwards, de-energize power to the unit, then swap two of the three incoming electrical lines to obtain proper phasing. Re-check.
- Perform all start up procedures outlined in the installation manual shipped with the unit.
- Fill in the Start Up Information as outlined on the opposite side of this sheet.
- Provide owner with information packet. Explain the thermostat and unit operation.